





Sauberer Zündvorgang durch optimale Hitze.



Zubehör IGNITER

Technische Daten		IGNITER BM4						BM4 mit M14 Schraub- adapter	BR4
Spannung	V	120	120	230	230	230	230	230	230
Frequenz	Hz	50 / 60							
Leistung	W	1100	1550	600	1100	1600	1100	3400	
Min. Luftmenge	l/min 20°C	230	230	80	230	230	230	360	
Luftdruck	kPa	2.48	2.48	0.3	2.48	2.48	2.48	4.00	
Max. Temperatur	°C	600	600	500	600	600	600	650	
Emissionspegel	dB (A)	68	68	58	68	68	68	68	
Durchmesser	mm Ø	90							
Gewicht	kg	1.0 (ohne Netzanschlussleitung)							1.2
Länge	mm	283							294
Konformitätszeichen		CE c RU us							CE
Sicherheitszeichen		Ⓢ							
Zertifizierung		CCA							
Schutzklasse II		□							
Artikelnummern		141.882	141.881	139.232	140.711	139.231	144.012	146.296	

Technische Änderungen vorbehalten.
Stecker und Kabelverbindungen nicht inklusive.

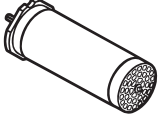
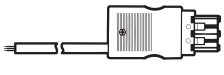
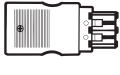
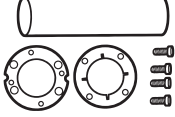
	142.414	Zubehör-Schraubadapter für Verlängerungen M 14
	153.245	Edelstahl Filter Kit (Ø 38 mm), aufschiebbar auf Ansaugstutzen
	107.286	Luftschlauch Ø 38 mm
	107.287	Schlauchbride
	142.717 150.871 150.872 142.718 150.873 145.606	Heizelement 230V ~ 1550 W Heizelement 230V ~ 1050 W Heizelement 230V ~ 550 W Heizelement 120V ~ 1500 W Heizelement 120V ~ 1050 W Heizelement (BR4) 230V ~ 3300 W
	142.967 143.131	Kabel (Gummi) mit WAGO-Stecker, 3x 1 mm ² x 3 m Kabel (Silikon) mit WAGO-Stecker, 3x 1 mm ² x 3 m
	142.976 148.429 (BR4)	Stecker mit Zugentlastung, kit (WAGO 770) für Kabel Ø 4.5 – 8 mm Stecker mit Zugentlastung, kit (WAGO 770) für Kabel Ø 8 – 11.5 mm
	142.359	Zubehör-Adapter-Set für Heizrohr des TRIAC S ECONOMY

Einbaumasse in mm

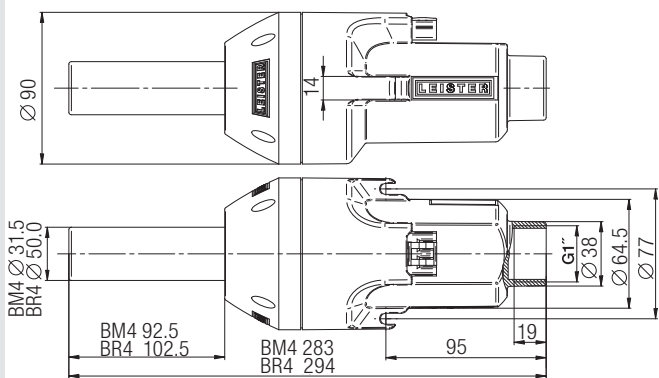

Einbau schematisch