

LEISTER®



LHS 91 BASIC SYSTEM



Leister Process Technologies
Galileo-Strasse 10
CH-6056 Kaegiswil/Switzerland

Tel. +41 41 662 74 74

Fax +41 41 662 74 16

www.leister.com
sales@leister.com

D	Deutsch	Bedienungsanleitung	3
GB	English	Operating Instructions	12
I	Italiano	Istruzioni d'uso	21
F	Français	Instructions d'utilisation	30
E	Español	Instrucciones de funcionamiento	39
TR	Türkçe	Kullanım kılavuzu	48



Bedienungsanleitung vor Inbetriebnahme aufmerksam lesen und zur weiteren Verfügung aufbewahren.

LHS 91 BASIC / LHS 91 SYSTEM Lufterhitzer

Anwendung

Die Leister Lufterhitzer LHS 91 BASIC und LHS 91 SYSTEM eignen sich für den Einbau in Maschinen, Anlagen oder Geräten und sind für den Dauerbetrieb ausgelegt.

- **Trocken- und Aufheizprozesse** verschiedenster Art
- **Schrumpfen und Schweissen** von Verpackungsfolien und Formteilen
- **Heizen** von Durchlauföfen und Behältern
- **Aktivieren und Lösen** von lösungsmittelfreien Klebstoffen und Schmelzklebern
- **Sterilisieren** von Verpackungsmaterialien wie Flaschen, Korken und Behältern
- **Trennen und Verschmelzen** von synthetischen Fäden und Geweben
- **Lötvorgänge** an dünnen Blechteilen
- **Beschleunigen** von Mischprozessen und **Auflösen** von Schäumen, die beim Mischen oder bei Abfüllvorgängen entstehen
- **Schweissen** von thermoplastischen Kunststoffen
- **Entfernen** von Kunststoff-Pressgrat
- **Glänzen** der Kunststoff-Oberflächen



Warnung



Lebensgefahr beim Öffnen des Gerätes, da spannungsführende Komponenten und Anschlüsse freigelegt werden. Vor dem Öffnen des Gerätes muss dieses allopolig vom Netz getrennt werden.



Feuer- und Explosionsgefahr bei unsachgemäßem Einbau und Gebrauch von Lufterhitzern, besonders in der Nähe von brennbaren Materialien und explosiven Gasen.



Verbrennungsgefahr! Heizelementrohr und Düse nicht in heissem Zustand berühren. Gerät abkühlen lassen. Heissluftstrahl nicht auf Personen oder Tiere richten.



Vorsicht



Nennspannung, die auf dem Gerät angegeben ist, muss mit der Netzspannung übereinstimmen.

IEC/EN 61000-3-11; $Z_{max} = 0.065\Omega + j 0.040\Omega$. Gegebenenfalls Elektrizitäts-Versorgungs-Unternehmen konsultieren.



Gerät der Schutzklasse I muss mit Schutzleiter geerdet werden.



Gerät **muss beobachtet** betrieben werden.

Wärme kann zu brennbaren Materialien gelangen, die sich ausser Sichtweite befinden. Gerät darf nur von **ausgebildeten Fachleuten** oder unter deren Aufsicht benutzt werden. Kindern ist die Benützung gänzlich untersagt.



Gerät **vor Feuchtigkeit und Nässe schützen.**

Einbauerklärung

(Im Sinne der EG-Maschinenrichtlinie 2006/42; Anhang II B)

Leister Process Technologies, Galileo-Strasse 10, CH-6056 Kaegiswil/Schweiz erklärt hiermit, dass die unvollständige Maschine

Bezeichnung: **Air Heater**
Typ: **LHS 91**
Ausführung: **BASIC oder SYSTEM**

– soweit es vom Lieferumfang her möglich ist – den anwendbaren grundlegenden Anforderungen der EG-Maschinenrichtlinie (2006/42) entspricht.

Die unvollständige Maschine entspricht überdies den Anforderungen der folgenden EG-Richtlinie(n):

EG-Richtlinie(n): Elektromagnetische Verträglichkeit 2004/108
Niederspannungsrichtlinie 2006/95

Harmonisierte Normen: EN 12100-1, EN 12100-2, EN 60204-1, EN 14121-1,
EN 55014-1, EN 55014-2, EN 61000-6-2,
EN 61000-3-12, EN 61000-3-11 (Z_{max}), EN 50366, EN 62233,
EN 60335-2-45

Ferner erklären wir, dass für diese unvollständige Maschine die speziellen technischen Unterlagen gemäss Anhang VII (Teil B) erstellt wurden und verpflichten uns, diese auf begründetes Verlangen den Marktüberwachungsbehörden elektronisch zu übermitteln.

Name des Dokumentationsbevollmächtigten: Patrick Rieder, Compliance Manager

Die Inbetriebnahme der unvollständigen Maschine wird so lange untersagt, bis gegebenenfalls festgestellt wurde, dass die Maschine, in die die unvollständige Maschine eingebaut wurde, den Bestimmungen der EG-Maschinenrichtlinie (2006/42) entspricht.

Kaegiswil, 01.07.2011

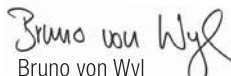
Bruno von Wyl
Technischer Direktor

Christiane Leister
Firmeninhaberin

Entsorgung



Elektrowerkzeuge, Zubehör und Verpackungen sollen einer umweltgerechten Wiederverwertung zugeführt werden. **Nur für EU-Länder:** Werfen Sie Elektrowerkzeuge nicht in den Hausmüll! Gemäß der Europäischen Richtlinie 2002/96 über Elektro- und Elektronik-Altgeräte und ihrer Umsetzung in nationales Recht müssen nicht mehr gebrauchsfähige Elektrowerkzeuge getrennt gesammelt und einer umweltgerechten Wiederverwertung zugeführt werden.

Technische Daten

Typ		BASIC		SYSTEM		
Spannung	V~	3 × 400	3 × 480	3 × 230	3 × 400	3 × 400
Frequenz	Hz	50/60		50/60		
Leistung	kW	32		28	11	32
Minimale Luftmenge	l/min.	3800		2200	1100	3100
Maximale Temperatur	°C	650		650		
Umgebungs-Temperatur	°C	<60		<60		
Max. Zuluft-Temperatur	°C	<50		<50		
Emissionspegel	L _{pA} (dB)	<70		<70		
Gewicht	kg	13.5		13.5		
Masse	mm	447 × 312 × 306		447 × 312 × 306		
Konformitätszeichen		CE		CE		
Sicherheitszeichen						
Zertifizierungsart						
Schutzklasse I		⊕		⊕		

Technische Änderungen vorbehalten

Gerätebeschreibung

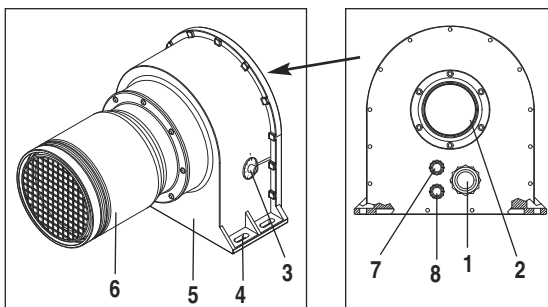

- 1 Kabelverschraubung für Netzanschluss
- 2 Einblasstutzen \varnothing 60 oder \varnothing 90
- 3 Potentiometer für Leistungseinstellung
- 4 Montagefuss
- 5 Gehäuse
- 6 Heizelementrohr mit Schutzrohr
- 7 Kabelverschraubung für Steuerungsanschluss 4–20 mA oder 0–10 V
- 8 Kabelverschraubung für Alarmkontakt

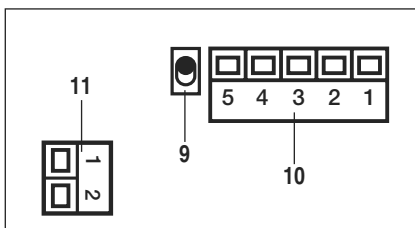

- 9 Umschalter Potentiometer / Schnittstelle
Unten: Potentiometer
Oben: Schnittstelle
- 10 Schnittstelle
- 11 Alarmkontakt

Einbau

- Das Gerät muss mit vier Schrauben am **Montagefuss (4)** befestigt werden.
- Der Einbau muss gewährleisten, dass
 - nur kalte Luft zugeführt wird
 - kein (Wärme-) Rückstau entsteht
 - das Gerät nicht vom Heissluftstrahl eines anderen Gerätes angeströmt wird.
- Das Gerät vor mechanischen Vibrationen und Erschütterungen schützen.

Einbaumasse in mm

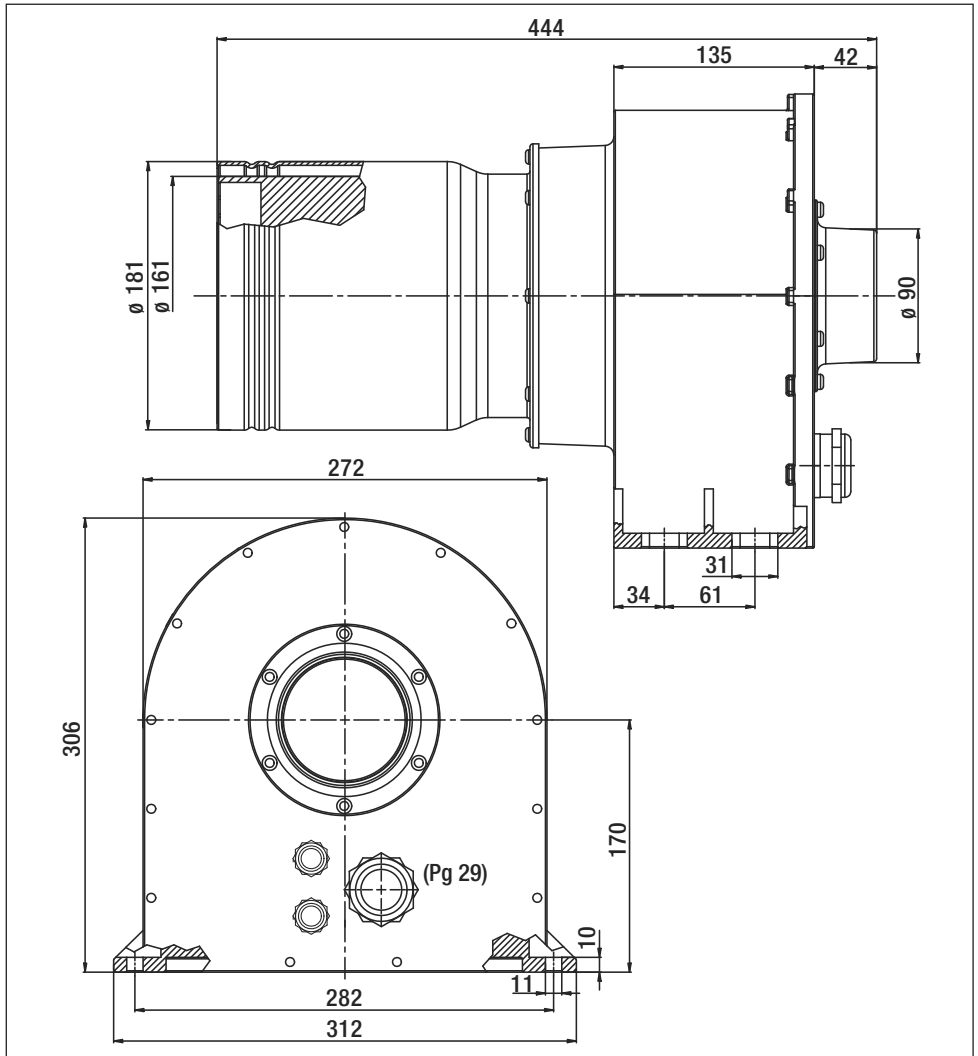

Luftversorgung

- Um Gerät und Heizelement zu schützen, darf die vorgeschriebene minimale Luftmenge keinesfalls unterschritten und die maximale Temperatur (heissester Punkt 3 mm vor dem **Heizelementrohr (6)** gemessen) keinesfalls überschritten werden. Falls die minimale Luftmenge unterschritten wird, muss sofort die Heizleistung unterbrochen werden.
- Luftdurchflussrichtung beachten.
- Die vorgeschriebene maximale Zulufttemperatur nicht überschreiten !
- Als Luftversorgung müssen Leister-Gebläse verwendet werden (Drehrichtung und Kompressionserwärmung beachten).
- Bei staubhaltiger Luft Leister-Edelstahlfilter am Gebläse-Ansaugstutzen verwenden. Bei besonders kritischen Stäuben (z.B. elektrisch leitende, feuchte, oder Metall-Stäube) müssen spezielle Filter verwendet werden, um Kurzschlüsse im Gerät zu vermeiden.

Achtung: Gerät immer mit Luftversorgung betreiben !

Anschlusschema Leistungsteil

- Das Gerät muss gemäss Anschlusschema durch Fachpersonen angeschlossen werden.
- Die Netzanschlussleitung muss entsprechenden Leiterquerschnitt aufweisen.
- Es muss sicher gestellt sein, dass die Anschlussleitungen das Heizelementrohr nicht berühren und nicht dem Heissluftstrahl ausgesetzt sind.

S1: Im Netzanschluss muss eine geeignete Vorrichtung zur allpoligen Trennung vom Netz mit einem **Kontaktabstand von 3 mm vorhanden sein.**

Anschlusschema:

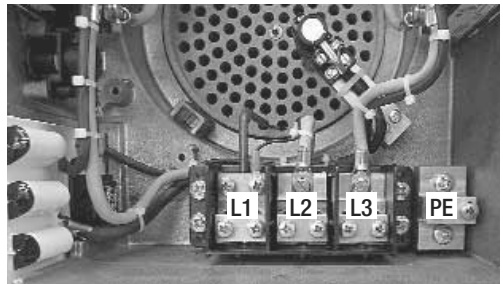
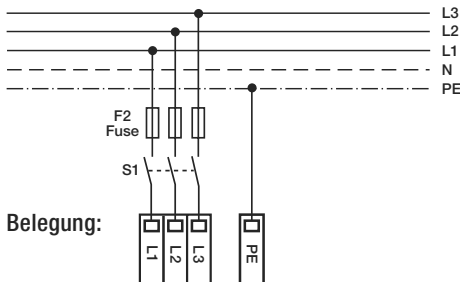

Systemschnittstelle LHS 91 SYSTEM

Die Leistung des Gerätes kann über die **Schnittstelle (10)** mit den Signalen I_C 4–20 mA oder U_C 0–10 V gesteuert werden. Zusätzlich wird eine Speisung U_S 15–26VDC benötigt. Der **Schalter (9)** muss nach oben gelegt sein.

Pinbelegung (10)

1	U_S GND
2	U_C 0–10V
3	I_C 4–20 mA
4	I_C GND
5	U_S

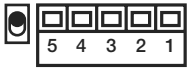

Technische Daten

Speisung	U_S	15–26 VDC
	U_S Max.	26 VDC
	Stromaufnahme bei 24 VDC	12 mA
Steuerstrom	I_C	4–20 mA DC
	I_C Ripple Max.	< 0.1 mA DC
	I_C Max.	22 mA DC
	Eingangswiderstand (typ.)	230 Ohm
Steuerspannung	U_C	0–10 VDC
	U_C Ripple Max.	< 0.05 VDC
	U_C Max.	12 VDC
	Eingangswiderstand (typ.)	280 kOhm

Ansteuerung 4–20 mA

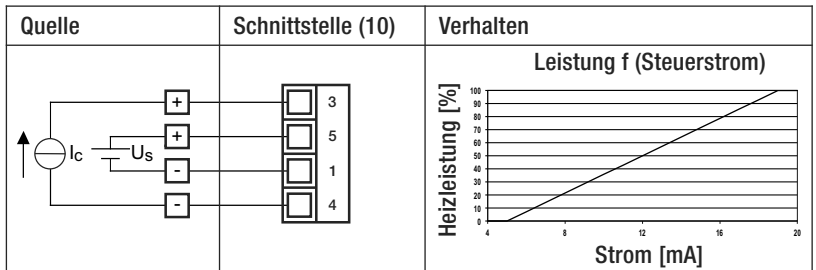

Ansteuerung 0–10 VDC

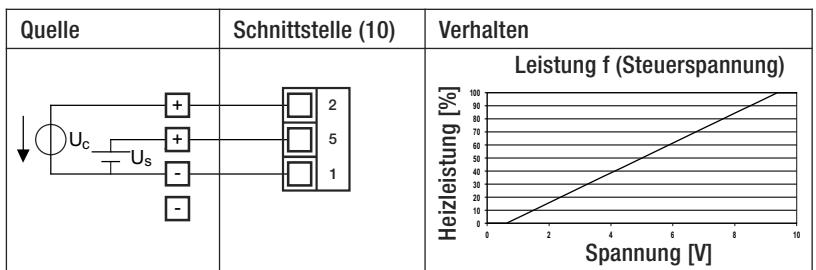

Alarm LHS 91 SYSTEM

Technische Daten:

Relaiskontakt SPST - NO

250V / 30VDC, 3A $\cos \varphi = 1$

Pinbelegung (11)

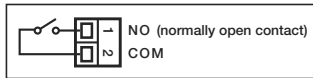

Geregelte Anwendung LHS 91 SYSTEM

Temperature controller CSS

4–20 [mA]
0–10 [V]

LHS 91 SYSTEM



Thermocouple

Gesteuerte Anwendung LHS 91 SYSTEM

Temperature controller CSS

4–20 [mA]
0–10 [V]
0–100 %

LHS 91 SYSTEM



Externes Potentiometer

4–20 [mA]
0–10 [V]
0–100 %

LHS 91 SYSTEM



Betrieb

- Nach Bedarf entsprechende Düse oder Reflektor montieren.
- Es muss darauf geachtet werden, dass die Heissluft frei ausströmen kann, da das Gerät ansonsten durch Wärmerückstau Schaden erleiden kann (Brandgefahr!).
- ACHTUNG: Minimale Luftmenge gemäss technischen Daten einhalten.
- Netz einschalten.
- Gerät nach dem Heizbetrieb nachkühlen lassen.

Bedienung LHS 91 BASIC

Die Temperatur kann nur durch die vom Anwender zugeführte Luftmenge beeinflusst werden.



ACHTUNG: Minimale Luftmenge nicht unterschreiten (siehe technische Daten)! Das Gerät ist nicht mit Heizelement- und Geräteschutz ausgerüstet!

Bedienung LHS 91 SYSTEM

1. Heizleistung mit **Potentiometer für Leistungseinstellung (3)** stufenlos einstellbar.

HINWEIS: **Schalter (9)** muss nach unten gelegt sein.

oder

2. Heizleistung über **Steuerungsanschluss (7)** mit **Schnittstelle (10)** stufenlos einstellbar.

HINWEIS: **Schalter (9)** muss nach oben gelegt sein.

- **Funktion Heizelementschutz**

Droht das Heizelement zu überhitzen, wird die Leistungszufuhr zum Heizelement reduziert.

- **Funktion Geräteschutz**

Droht das Gerät zu überhitzen (zu warme Zuluft, Wärmerückstau, fehlende Luft), wird die Leistungszufuhr zum Heizelement unterbrochen und der Arbeitskontakt des **Alarmrelais (11)** geöffnet. Dieser kann optional zur Fehlererkennung ausgewertet werden.

- **Massnahmen beim Ansprechen des Geräteschutzes**

- Damit das Gerät neu gestartet werden kann, muss es 5 Sekunden vom elektrischen Netz getrennt werden.
- Luftzufuhr überprüfen.
- Luftmenge überprüfen.
- Luftdurchlass überprüfen.
- Gerät wieder mit dem elektrischen Netz verbinden.



Düsen- oder Reflektorwechsel



Verbrennungsgefahr! Heizelementrohr und Düse nicht in heissem Zustand berühren. Beim Wechseln von Düse oder Reflektor zuvor Gerät abkühlen lassen.

Schulung

Leister Process Technologies sowie deren autorisierte Service-Stellen bieten kostenlose Kurse im Bereich der Anwendungen an.

3D Zeichnungen

3D-Zeichnungen der Luffterhitzer LHS-Linie sind bei ihrer Service-Stelle oder auf www.leister.com erhältlich.

Zubehör

Es darf nur Leister-Zubehör verwendet werden.

- Leister bietet ein grosses Sortiment an Zubehör, z.B.
 - Temperaturregler
 - Düsen
 - Gebläse
- Zubehör unter www.leister.com

Service und Reparatur

- Reparaturen sind ausschliesslich von autorisierten **Leister-Service-Stellen** ausführen zu lassen. Diese gewährleisten innert nützlicher Frist einen fachgerechten und zuverlässigen **Reparatur-Service** mit Original-Ersatzteilen gemäss Schaltplänen und Ersatzteillisten.

Gewährleistung

- Für dieses Gerät besteht eine grundsätzliche Gewährleistung von einem (1) Jahr ab Kaufdatum (Nachweis durch Rechnung oder Lieferschein). Entstandene Schäden werden durch Ersatzlieferung oder Reparatur beseitigt. Heizelemente sind von dieser Gewährleistung ausgeschlossen.
- Weitere Ansprüche sind, vorbehältlich gesetzlicher Bestimmungen, ausgeschlossen.
- Schäden, die auf natürliche Abnutzung, Überlastung oder unsachgemässe Behandlung zurückzuführen sind, werden von der Gewährleistung ausgeschlossen.
- Keine Ansprüche bestehen bei Geräten, die vom Käufer umgebaut oder verändert worden sind.



Please read operating instructions carefully before use and keep for future reference.

LHS 91 BASIC / LHS 91 SYSTEM

Air heaters

Application

The Leister air heaters LHS 91 BASIC and LHS 91 SYSTEM are suitable for installation in machines, systems or devices and are designed for continuous operation.

- Diverse types of **drying and heating processes**
- **Shrinking and welding** of packaging films and formed parts
- **Heating** of continuous furnaces and vessels
- **Activation and dissolving** of solvent-free adhesives and hot-melt adhesives
- **Sterilisation** of packaging materials such as bottles, corks and containers
- **Separation and fusing** of synthetic threads and fabrics
- **Soldering processes** on thin sheet metal parts
- **Acceleration** of mixing processes and **removal** of foams resulting during mixing or filling processes
- **Welding** of thermoplastics
- **Removal** of plastic flashing
- **Brightening** of plastic surfaces



Warning



Danger of death when opening the device, as live parts and connections are exposed. The device must be fully disconnected from the mains before opening it.



Danger of fire and explosion if air heaters are installed and used incorrectly, especially in the vicinity of flammable materials and explosive gases.



Danger – can cause burns! Do not touch the heating element tube and nozzle while they are hot. Allow the device to cool. Do not direct hot-air stream towards people or animals.



Caution



The **nominal voltage** indicated on the device must correspond to the mains voltage. IEC/EN 61000-3-11; $Z_{max} = 0.065\Omega + j 0.040\Omega$. If necessary, consult your electricity supply utility.



Devices of protection class I must be earthed with a protective earth conductor.



The device **must not be left unattended** when in use. Heat can reach combustible materials which are out of sight. The device may only be used by **trained personnel** or under their supervision. Children may not use the device under any circumstances.



Keep **away from wet and damp areas.**

Installation declaration

(in terms of the EC machinery directive 2006/42; Appendix II B)

Leister Process Technologies, Galileo-Strasse 10, CH-6056 Kaegiswil/Switzerland hereby declares the partly completed machinery

Designation : **Air Heater**
Type: **LHS 91**
Option: **BASIC or SYSTEM**

– as far as it is possible from the scope of supply – fulfills the applicable essential requirements of the EC machinery directive (2006/42).

The partly completed machinery furthermore complies with the provisions of the following EC directive(s):

EC directive(s): Electromagnetic compatibility 2004/108
Low voltage equipment 2006/95

Harmonised standards: EN 12100-1, EN 12100-2, EN 60204-1, EN 14121-1,
EN 55014-1, EN 55014-2, EN 61000-6-2,
EN 61000-3-12, EN 61000-3-11 (Z_{max}), EN 50366, EN 62233,
EN 60335-2-45

In addition, we declare the relevant technical documentation for this partly completed machinery is compiled in accordance with Annex VII (part B) and will be electronically transmitted to national authorities in response to a reasoned request. Authorised documentation representative: Patrick Rieder, Compliance Manager

The partly completed machine must not be put into service until the final machinery into which it is to be incorporated has been declared in conformity with the provisions of the EC machinery directive (2006/42), where appropriate.

Kaegiswil, 01.07.2011

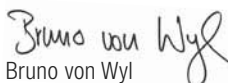
Bruno von Wyl
Technical Director

Christiane Leister
Company Owner

Disposal



Power tools, accessories and packaging should be recycled. **For EU countries only:** do not dispose of power tools in your household rubbish! According to the European Directive 2002/96 on waste electrical and electric equipment and its implementation in national law, power tools which can no longer be used must be collected separately and recycled.

Technical Data

Type		BASIC		SYSTEM		
Voltage	V~	3 × 400	3 × 480	3 × 230	3 × 400	3 × 400
Frequency	Hz	50/60		50/60		
Power	kW	32		28	11	32
Minimum air volume	l/min.	3800		2200	1100	3100
Maximum temperature	°C	650		650		
Ambient temperature	°C	<60		<60		
Max. inlet air temperature	°C	<50		<50		
Emission level	L _{pA} (dB)	<70		<70		
Weight	kg	13.5		13.5		
Dimensions	mm	447 × 312 × 306		447 × 312 × 306		
Conformity mark		CE		CE		
Safety standard						
Type of certification						
Protection class I		⊕		⊕		

The right to make technical changes is reserved

Device Description

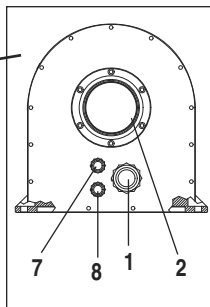
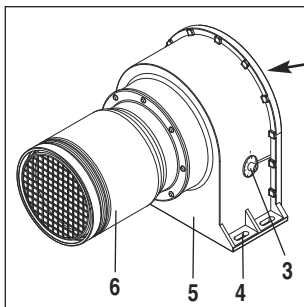

- 1 Cable gland for mains connection
- 2 Air-inlet nozzle \varnothing 60 or \varnothing 90
- 3 Potentiometer for power setting
- 4 Assembly foot
- 5 Housing
- 6 Heating element pipe with protective tube
- 7 Cable gland for control connection
4–20 mA or 0–10 V
- 8 Cable gland for alarm contact
- 9 Potentiometer / Interface switch
Down: Potentiometer
Up: Interface
- 10 Interface
- 11 Alarm contact

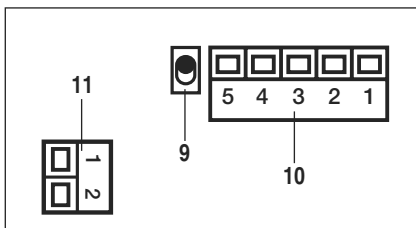

Installation

- The device must be fastened with four screws on the **assembly foot (4)**
- The installation must ensure that
 - only cold air is supplied
 - no excess (heat) residue builds up
 - the device is not subject to jets of hot air from another device.
- Protect the device from mechanical vibrations and shocks.

Installation dimensions in mm

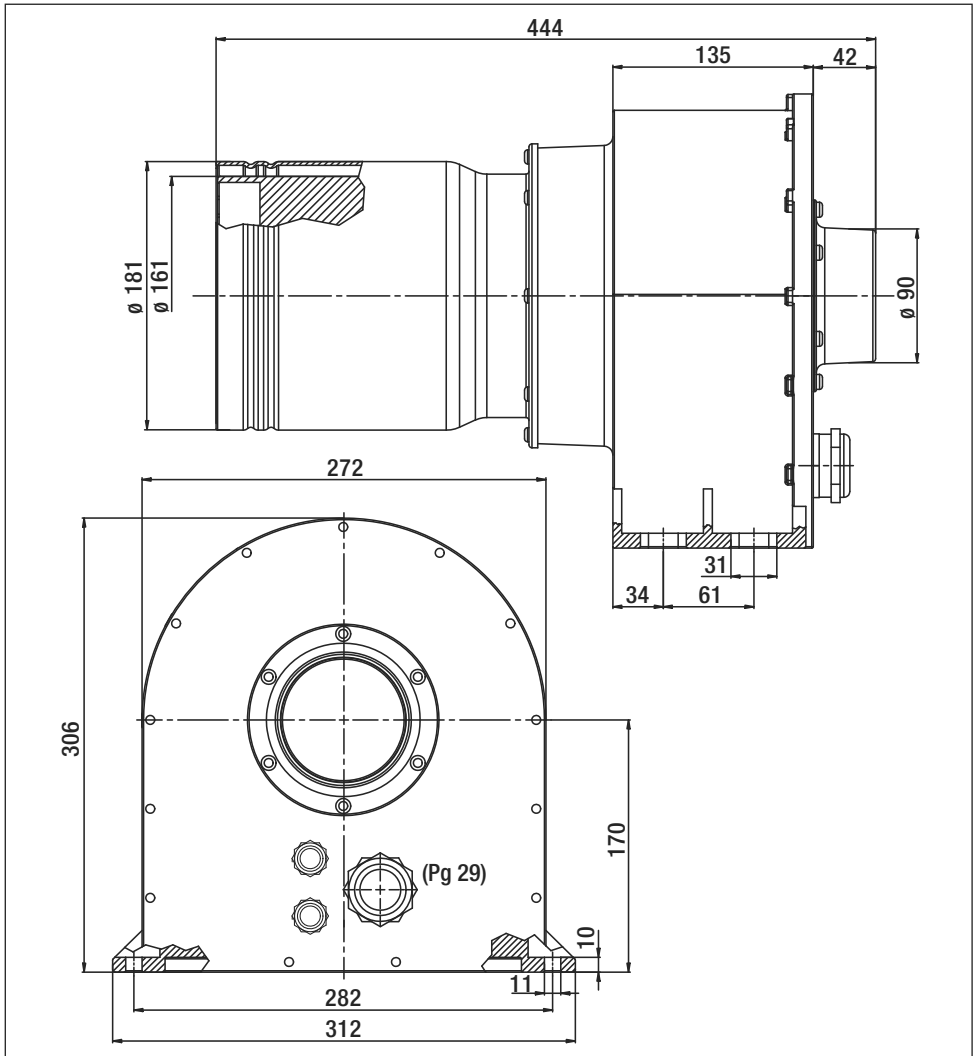

Air supply

- In order to protect the device and heating element, the specified minimum air volume must never be fallen below and the maximum temperature (hottest point measured 3 mm before the **heating element tube (6)**) must never be exceeded. If the minimum air volume is fallen below, the heat output must be interrupted immediately.
- Observe direction of air flow.
- Do not exceed the specified maximum inlet air temperature!
- Leister blowers must be used as an air supply (observe direction of rotation and compression preheating).
- Use a Leister stainless steel filter on the blower air intake if the air contains dust. In the case of critical dusts (e.g. electrically conductive, damp or metal dusts), special filters must be used to avoid short-circuits in the device.

Attention: Always operate device with air supply !

Wiring diagram

- The device must be connected by a qualified expert in accordance with the connection diagram.
- The mains connection must have a sufficient wire cross-section.
- It must be ensured that the connection lines do not come into contact with the heating element tube and are not exposed to the hot air jet.

S1: A suitable device for full disconnection from the mains with a **contact distance of 3 mm** must be provided in the mains connection.

Connection diagram:

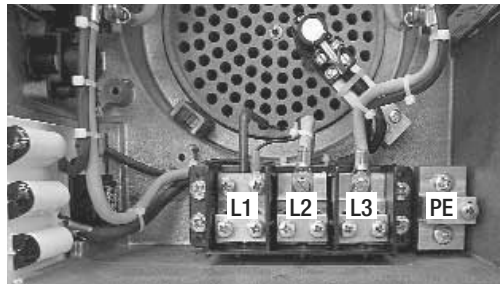
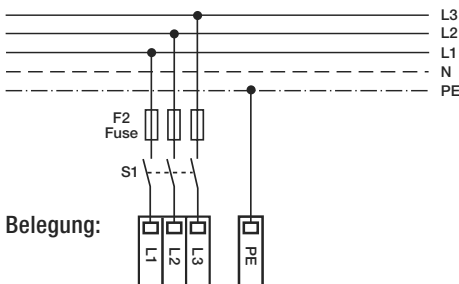

System interface LHS 91 SYSTEM

The power of the unit can be controlled via the **interface (10)** with the signals I_C 4–20 mA or U_C 0–10 V. A supply voltage of US 15–26VDC is also required. The **switch (9)** must be put on upper position.

Pin assignment (10)

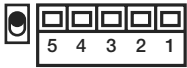
1	U_S GND	
2	U_C 0–10V	
3	I_C 4–20 mA	
4	I_C GND	
5	U_S	

Technical Data

Supply voltage	U_S	15–26 VDC
	U_S max.	26 VDC
	Power consumption at 24 VDC	12 mA
Control current	I_C	4–20 mA DC
	I_C ripple max.	< 0.1 mA DC
	I_C max.	22 mA DC
	Input resistance (type)	230 Ohm
Control voltage	U_C	0–10 VDC
	U_C ripple max.	< 0.05 VDC
	U_C max.	12 VDC
	Input resistance (type)	280 kOhm

Control signal 4–20 mA

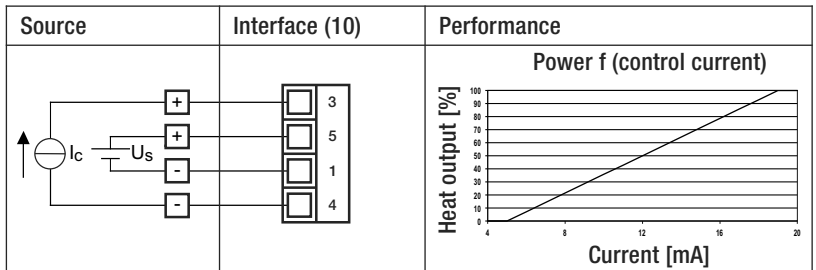

Control signal 0–10 VDC

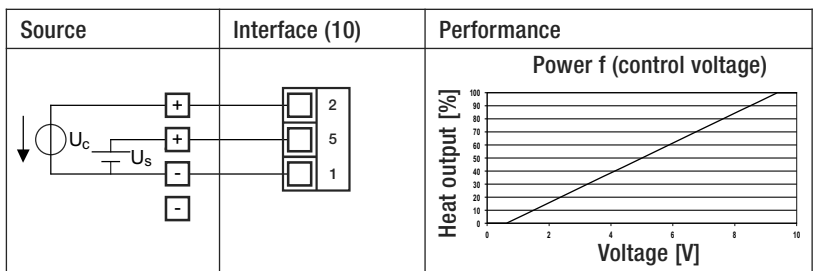

Alarm LHS 91 SYSTEM

Technical Data:

Relay contact SPST - NO
250V / 30 VDC, 3A $\cos \varphi = 1$

Pin assignment (11)

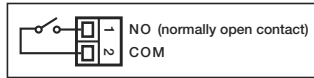

Closed loop control LHS 91 SYSTEM

Temperature controller CSS

4–20 [mA]
0–10 [V]

LHS 91 SYSTEM



Thermocouple

Open loop control LHS 91 SYSTEM

Temperature controller CSS

4–20 [mA]
0–10 [V]
0–100 %

LHS 91 SYSTEM



External potentiometer

4–20 [mA]
0–10 [V]
0–100 %

LHS 91 SYSTEM



Operation

- Mount corresponding nozzle or reflector, if required.
- It must be ensured that the hot air can flow out freely, as otherwise the device can be damaged by the excess heat building up (risk of fire !).
- ATTENTION: Comply with minimum air volume as per technical data.
- Switch on mains.
- Allow device to cool down after heating mode.

Operation LHS 91 BASIC

The temperature can only be influenced by the air volume supplied by the user.



ATTENTION: Do not fall below the minimum air volume (see technical data) !
The device is not fitted with heating element and device protection !

Operation LHS 91 SYSTEM

1. Heating power infinitely adjustable with **potentiometer for power setting (3)**.

NOTE: The **switch (9)** must be put on lower position.

or

2. Heating power infinitely adjustable via **control connection (7)** with **interface (10)**.

NOTE: The **switch (9)** must be put on upper position.

- **Heating element protection function**

If there is a risk of the heating element overheating, the power supply to the heating element will be reduced.

- **Device protection function**

If there is a risk of the device overheating (too hot inlet air, excess heat reside, absence of air), the power supply to the heating element will be interrupted and the working contact of the **alarm relay (11)** opened. This can optionally be evaluated for fault detection.

- **Actions when the device protection responds**

- The device must be disconnected from the electrical power supply for 5 seconds so that it can be restarted.
- Check air supply.
- Check air volume.
- Check air flow.
- Reconnect device to the electrical power supply.



Changing the nozzle or reflector



Danger – can cause burns! Do not touch the heating element tube and nozzle while they are hot.
Allow the device to cool down before replacing the nozzle / reflector.

Training

Leister Process Technologies and its authorised service points provide free application courses.

3D drawings

3D drawings of the LHS line air heaters are available from your service point or at www.leister.com

Accessories

Only Leister accessories may be used.

- Leister offers a wide range of accessories, e.g.
 - Temperature controls
 - Nozzles
 - Blowers
- Accessories at www.leister.com

Service and Repairs

- Repairs should only be carried out by authorised **Leister Service Centres**. They guarantee a correct and reliable repair service within reasonable period, using original spare parts in accordance with the circuit diagrams and spare parts lists.

Warranty

- For this tool, we generally provide a warranty of one (1) year from the date of purchase (verified by invoice or delivery document). Damage that has occurred will be corrected by replacement or repair. Heating elements are excluded from this warranty.
- Additional claims shall be excluded, subject to statutory regulations.
- Damage caused by normal wear, overloading or improper handling is excluded from the guarantee.
- Warranty claims will be rejected for tools that have been altered or changed by the purchaser.



Prima della messa in funzione, leggere attentamente le istruzioni per l'uso e conservarle per ulteriori consultazioni.

LHS 91 BASIC / LHS 91 SYSTEM

Riscaldatore d'aria

Modalità d'impiego

I riscaldatori d'aria Leister LHS 91 BASIC e LHS 91 SYSTEM sono adatti all'installazione in macchinari, impianti o apparecchi e sono progettati per il funzionamento continuo.

- **processi di riscaldamento ed essiccazione** di qualsiasi tipo
- **termoretrazione e saldatura** di film per imballaggi e stampi
- **riscaldamento** di forni elettrici continui e contenitori
- **attivazione e distacco** di collanti privi di solventi e adesivi termoplastici
- **sterilizzazione** di materiali per imballaggio, come bottiglie, tappi e contenitori
- **separazione e fusione** di fili e tessuti sintetici
- **processi di saldatura** su lamiere sottili
- **accelerazione** di processi di miscelazione e **dissolvimento** di schiume che si formano durante la miscelazione o i processi di riempimento
- **saldatura** di materiali termoplastici
- **eliminazione** di bave di stampaggio in materiale plastico
- **lucidatura** di superfici in plastica



Avvertenza



All'apertura dell'apparecchio sussiste il **pericolo di morte** perché vengono esposti componenti e collegamenti sotto tensione. Prima dell'apertura dell'apparecchio, si devono staccare tutti i poli dalla rete.



Sussiste il **pericolo di incendio e di esplosione** in caso di montaggio e utilizzo improprio di riscaldatori, in particolare nelle vicinanze di materiali infiammabili e gas esplosivi.



Pericolo di ustione: non toccare il tubo della resistenza e l'ugello quando sono ancora bollenti. Lasciare raffreddare l'apparecchio. Non orientare il getto di aria calda verso persone o animali.



Cautela



La **tensione nominale** specificata sull'apparecchio deve coincidere con la tensione di rete.

IEC/EN 61000-3-11; $Z_{max} = 0.065\Omega + j 0.040\Omega$. Eventualmente consultare l'azienda erogatrice di elettricità.



Gli apparecchi della classe di isolamento I devono essere messi a terra con un conduttore di terra.



È **necessario mantenere** l'apparecchio **sotto controllo** durante il funzionamento. Il calore può raggiungere materiali infiammabili che si trovano fuori dal campo visivo. L'impiego dell'apparecchio è consentito esclusivamente a **personale specializzato** o sotto il monitoraggio di quest'ultimo. È tassativamente vietato l'impiego da parte dei bambini.



Proteggere l'apparecchio **da umidità e da ambienti bagnati.**

Dichiarazione di montaggio

(ai sensi della direttiva macchine CE 2006/42, allegato II B)

Con il presente documento **Leister Process Technologies, Galileostrasse 10, CH-6056 Kaegiswil/Svizzera** dichiara che la quasi-macchina

Descrizione: **Air Heater**
Modello: **LHS 91**
Versione: **BASIC o SYSTEM**

– soddisfa i requisiti fondamentali applicabili della direttiva macchine CE (2006/42), a seconda delle possibilità previste dalla fornitura.

La quasi-macchina soddisfa inoltre i requisiti della/e direttiva/e CE riportata/e di seguito:

Direttiva (o direttive) CE: compatibilità elettromagnetica 2004/108
bassa tensione 2006/95
Norme armonizzate: EN 12100-1, EN 12100-2, EN 60204-1, EN 14121-1,
EN 55014-1, EN 55014-2, EN 61000-6-2,
EN 61000-3-12, EN 61000-3-11 (Z_{max}), EN 50366, EN 62233,
EN 60335-2-45

Inoltre si dichiara di aver redatto la documentazione tecnica specifica ai sensi dell'allegato VII (parte B) per la presente quasi-macchina con l'obbligo di trasmetterla su richiesta motivata in formato elettronico alle autorità competenti del monitoraggio del mercato.

Nominativo del responsabile della documentazione: Patrick Rieder, Compliance Manager

La messa in funzione della quasi-macchina è vietata finché non sia stato eventualmente accertato che la macchina, in cui è stata installata la quasi-macchina, soddisfi le disposizioni della direttiva macchine CE (2006/42).

Kaegiswil, 01.07.2011

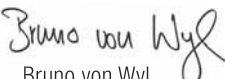
Bruno von Wyl
Direttore tecnico

Christiane Leister
Titolare dell'azienda

Smaltimento



Gli apparecchi elettrici, gli accessori e gli imballaggi devono essere riciclati nel rispetto dell'ambiente. **Solo per i Paesi UE:** non smaltire gli apparecchi elettrici insieme ai rifiuti domestici. Ai sensi della direttiva europea 2002/96 sui rifiuti di apparecchiature elettriche ed elettroniche e del relativo recepimento nella legislazione nazionale, è necessario raccogliere separatamente gli apparecchi elettrici non più utilizzabili e conferirli in un sistema di riciclaggio a basso impatto ambientale.

Specifiche tecniche

Modello		BASIC		SYSTEM		
Tensione	V~	3 × 400	3 × 480	3 × 230	3 × 400	3 × 400
Frequenza	Hz	50/60		50/60		
Potenza	kW	32		28	11	32
Portata minima d'aria	l/min.	3800		2200	1100	3100
Temperatura massim	°C	650		650		
Temperatura ambiente	°C	<60		<60		
Temperatura di entrata dell'aria max.	°C	<50		<50		
Livello di emissioni acustiche	L _{pA} (dB)	<70		<70		
Peso	kg	13.5		13.5		
Dimensioni	mm	447 × 312 × 306		447 × 312 × 306		
Marchio di conformità		CE		CE		
Marchio di sicurezza						
Tipo di certificazione						
Classe di isolamento I		⊕		⊕		
Con riserva di modifiche tecniche						

Descrizione dell'apparecchio

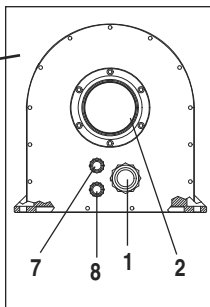
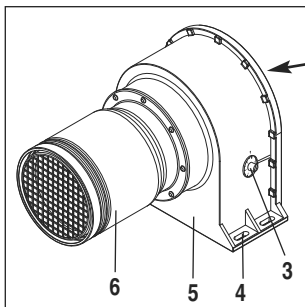

- 1 Passacavo a vite per allacciamento alla rete
- 2 Bocchettone di immissione \varnothing 60 o \varnothing 90
- 3 Potenziometro per regolazione di potenza
- 4 Piedino di montaggio
- 5 Alloggiamento
- 6 Tubo della resistenza con guaina
- 7 Passacavo a vite per allacciamento della corrente di controllo 4–20 mA o 0–10 V
- 8 Passacavo a vite per contatto di allarme
- 9 Commutatore potenziometro/interfaccia
In basso: potenziometro
In alto: interfaccia
- 10 Interfaccia
- 11 Contatto di allarme

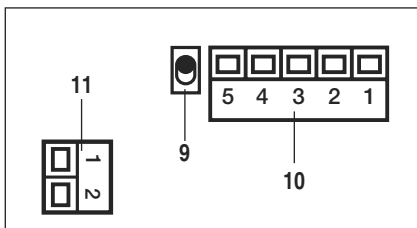

Montaggio

- L'apparecchio deve essere fissato al **piedino di montaggio (4)** con quattro viti.
- Il montaggio deve garantire che
 - venga erogata solo aria fredda
 - non si formi alcun ristagno (di calore)
 - l'apparecchio non sia interessato da un getto di aria calda di un altro apparecchio
- Proteggere l'apparecchio da vibrazioni meccaniche e sollecitazioni.

Misura d'ingombro in mm

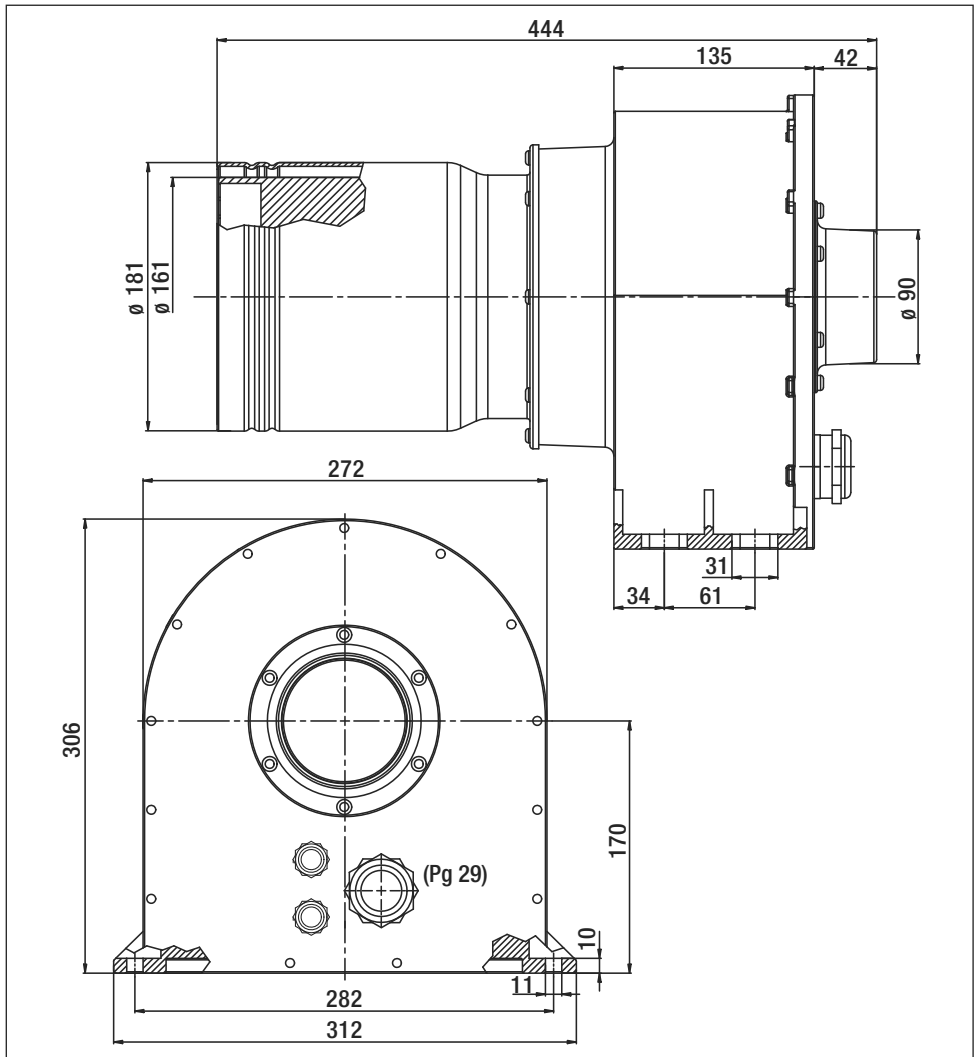

Alimentazione d'aria

- Per proteggere l'apparecchio e la resistenza, non si deve in alcun caso scendere sotto la portata d'aria minima prescritta né superare la temperatura massima (il punto più caldo viene misurato a 3 mm prima del **tubo della resistenza (6)**). In caso di mancato raggiungimento della portata d'aria minima, si deve immediatamente interrompere la potenza di riscaldamento.
- Osservare la direzione di flusso dell'aria.
- Non superare la temperatura d'entrata massima prescritta!
- Per l'alimentazione d'aria si devono utilizzare ventilatori Leister (osservando la direzione di rotazione e il riscaldamento per compressione).
- In presenza di aria contenente polvere, utilizzare filtri in acciaio inossidabile Leister sul raccordo di aspirazione del ventilatore. In presenza di polveri particolarmente critiche (per esempio, polveri metalliche, umide o a conduzione elettrica) si devono utilizzare filtri speciali al fine di evitare cortocircuiti nell'apparecchio.

Attenzione: far funzionare sempre l'apparecchio con alimentazione d'aria!

Schema di allacciamento, elemento di potenza

- L'apparecchio deve essere allacciato da personale specializzato secondo lo schema di allacciamento.
- I cavi di allacciamento alla rete devono presentare una sezione del cavo corrispondente.
- Si deve garantire che i cavi di allacciamento non tocchino il tubo della resistenza e che non siano esposti al getto di aria calda.

S1: Nell'allacciamento alla rete deve essere presente un idoneo dispositivo per il distacco onnipolare dalla rete con una **distanza di contatto di 3 mm**.

Schema di allacciamento:

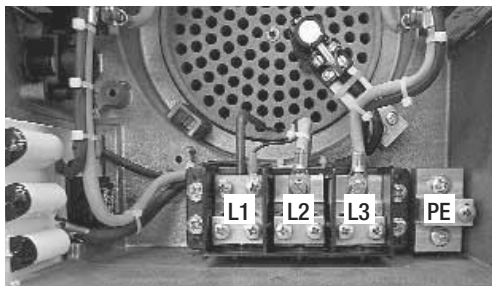
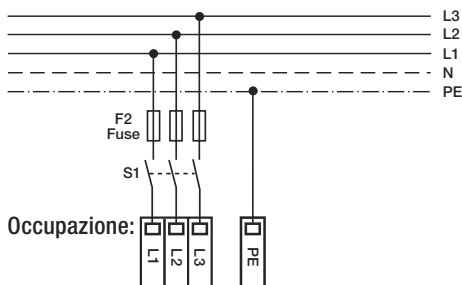

Interfaccia di LHS 91 SYSTEM

La potenza dell'apparecchio può essere controllata mediante l'**interfaccia (10)** con i segnali I_C 4–20 mA o U_C 0–10 V. Inoltre è necessaria un'alimentazione U_S 15–26 VDC. L'**interruttore (9)** deve essere posizionato verso l'alto.

Occupazione dei morsetti (10)

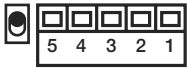
1	U_S GND	
2	U_C 0–10V	
3	I_C 4–20 mA	
4	I_C GND	
5	U_S	

Specifiche tecniche

Alimentazione	U_S	15–26 VDC
	U_S max.	26 VDC
	Assorbimento di corrente con 24 VDC	12 mA
Corrente di controllo	I_C	4–20 mA DC
	I_C Ripple max.	< 0.1 mA DC
	I_C max.	22 mA DC
	Resistenza d'ingresso (tip.)	230 Ohm
Tensione di controllo	U_C	0–10 VDC
	U_C Ripple max.	< 0.05 VDC
	U_C max.	12 VDC
	Resistenza d'ingresso (tip.)	280 kOhm

Sistema di controllo 4–20 mA

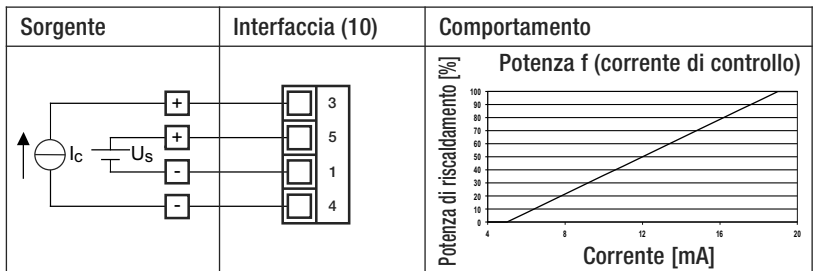

Sistema di controllo 0–10 VDC

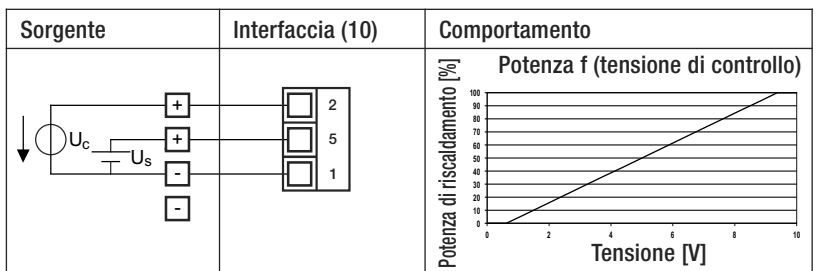

Allarme del LHS 91 SYSTEM

Specifiche tecniche:

Contatto del relè SPST - NO
250V / 30 VDC, 3A $\cos \varphi = 1$

Occupazione dei morsetti (11)

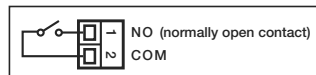

Applicazione regolata LHS 91 SYSTEM

Sensore di temperatura CSS

4–20 [mA]
0–10 [V]

LHS 91 SYSTEM



Termocoppia

Applicazione controllata LHS 91 SYSTEM

Sensore di temperatura CSS

4–20 [mA]
0–10 [V]
0–100 %

LHS 91 SYSTEM



Potenziometro esterno

4–20 [mA]
0–10 [V]
0–100 %

LHS 91 SYSTEM



Funzionamento

- Montare, se necessario, un ugello o un riflettore corrispondente.
- Si deve prestare attenzione affinché l'aria calda possa fluire liberamente in quanto altrimenti l'apparecchio potrebbe subire danni dovuti al ristagno termico (pericolo di incendio).
- **ATTENZIONE:** Rispettare la portata minima d'aria secondo i dati tecnici.
- Allacciare alla rete.
- Dopo il funzionamento lasciare raffreddare l'apparecchio.

Comando LHS 91 BASIC

La temperatura può essere influenzata solo dalla portata d'aria alimentata dall'utente.



ATTENZIONE: evitare il mancato raggiungimento della portata d'aria minima (vedi Dati tecnici)!
L'apparecchio non è dotato di dispositivo di protezione per l'apparecchio e per la resistenza!

Comando LHS 91 SYSTEM

1. Potenza di riscaldamento regolabile in modo continuo con il **potenziometro per la regolazione di potenza (3)**.
AVVERTENZA: l'**interruttore (9)** deve essere posizionato verso il basso.
Oppure
 2. Potenza di riscaldamento regolabile in modo continuo mediante l'**allacciamento della corrente di controllo (7)** con **interfaccia (10)**.
AVVERTENZA: l'**interruttore (9)** deve essere posizionato verso l'alto.
- **Funzionamento del dispositivo di protezione della resistenza**
Se la resistenza minaccia di surriscaldarsi, viene ridotta l'alimentazione di potenza alla resistenza.
 - **Funzionamento del dispositivo di protezione dell'apparecchio**
Se l'apparecchio minaccia di surriscaldarsi (aria d'ingresso troppo calda, ristagno termico, mancanza d'aria) viene sospesa l'alimentazione di potenza alla resistenza e il contatto del **relè d'allarme (11)** viene aperto. Esso può essere sottoposto in via opzionale a valutazione per il riconoscimento di errori.
 - **Misure in caso di attivazione del dispositivo di controllo dell'apparecchio**
 - Per poter riavviare l'apparecchio, esso deve essere staccato per 5 secondi dalla rete elettrica.



- Verificare l'apporto d'aria.
- Verificare la portata d'aria.
- Verificare la diffusione d'aria.
- Ricollegare l'apparecchio alla rete elettrica.

Sostituzione di ugelli o riflettori



Pericolo di ustione: non toccare il tubo della resistenza e l'ugello quando sono ancora bollenti. Per effettuare le operazioni di sostituzione degli ugelli o dei riflettori, lasciare raffreddare l'apparecchio.

Formazione

Leister Process Technologies e i rispettivi centri d'assistenza autorizzati offrono corsi gratuiti nell'ambito delle applicazioni.

Disegni 3D

I disegni 3D dei riscaldatori d'aria della linea LHS sono disponibili presso il centro d'assistenza di fiducia o su www.leister.com.

Accessori

È consentito utilizzare solo gli accessori Leister.

- Leister offre una vasta gamma di accessori, tra cui
 - regolatori di temperatura
 - ugelli
 - ventilatori
- Accessori all'indirizzo www.leister.com

Servizio di assistenza e riparazione

- Le riparazioni devono essere eseguite esclusivamente dai **centri di assistenza tecnica Leister** autorizzati. I centri di assistenza tecnica garantiscono un **servizio di riparazione** professionale ed affidabile con pezzi di ricambio originali conformi agli schemi elettrici e agli specifici elenchi.

Garanzia

- Questo apparecchio è coperto da una garanzia base di un (1) anno dalla data di acquisto (comprovata da fattura o bolla di consegna). In caso di danni la garanzia prevede la fornitura sostitutiva o la riparazione. Le resistenze sono escluse dalla garanzia.
- Sono esclusi eventuali altri diritti, fatte salve le disposizioni di legge.
- I danni, riconducibili alla naturale usura, al sovraccarico o all'uso improprio, vengono esclusi dalla garanzia.
- Non sono previsti eventuali diritti per quanto riguarda gli apparecchi sottoposti a modifiche o alterazioni da parte dell'acquirente.



Lisez attentivement la notice d'utilisation avant de mettre l'appareil en service et conservez-la à disposition pour une consultation ultérieure.

LHS 91 BASIC / LHS 91 SYSTEM

Chauffe-air

Application

Le chauffe-air LHS 91 BASIC et LHS 91 SYSTEM de Leister conviennent au montage dans des machines, installations ou appareils et sont conçus pour une utilisation en continu.

- **Processus de séchage et de chauffage** de différents types
- **Rétraction et soudage** de films d'emballage et de pièces moulées
- **Chauffage** de fours continus et de réservoirs
- **Activation et dissolution** de colles exemptes de solvants et de colles fusibles
- **Stérilisation** de matériaux d'emballage tels que les bouteilles, les bouchons et les réservoirs
- **Sectionnement et soudage** de fils synthétiques et de tissus
- **Processus de brasage** sur de fines pièces en tôle
- **Accélération** de processus de mélange et **dissolution** de mousses qui se créent lors du mélange ou des procédures de remplissage
- **Soudage** de thermoplastiques
- **Ebavurage** de matières plastiques
- **Lustrage** des surfaces en plastique



Avertissement



Danger de mort à l'ouverture de l'appareil, car des composants et des liaisons sous tension sont découverts. Avant d'ouvrir l'appareil, débranchez-le du secteur sur tous les pôles.



Risque d'incendie et d'explosion en cas de montage et d'utilisation non conformes de chauffe-air, en particulier à proximité de matériaux inflammables et de gaz explosifs.



Risque de brûlure ! Ne touchez pas le tuyau de la résistance et la buse s'ils sont chauds. Laissez refroidir l'appareil. Ne dirigez pas le jet d'air chaud sur les personnes ou les animaux.



Attention



La tension nominale indiquée sur l'appareil doit correspondre à la tension du secteur.

IEC/EN 61000-3-11; $Z_{max} = 0.065\Omega + j 0.040\Omega$. Le cas échéant, consultez l'entreprise de distribution d'électricité.



Les appareils de classe de protection I doivent être mis à la terre avec un conducteur de protection.



L'appareil **doit fonctionner sous supervision.**

La chaleur peut atteindre des matériaux inflammables se trouvant hors de portée de vue. L'appareil doit être utilisé exclusivement par des **spécialistes formés** ou sous leur supervision. L'utilisation de l'appareil par des enfants est strictement interdite.



Protégez l'appareil **de l'humidité et de la pluie.**

Déclaration d'incorporation

(Selon la Directive Machines 2006/42/CE ; Annexe II B)

Par la présente, **Leister Process Technologies, Galileostrasse 10, CH-6056 Kaegiswil/Suisse** déclare que la quasi-machine

Désignation: **Air Heater**
Type: **LHS 91**
Modèle: **BASIC ou SYSTEM**

– dans la mesure où l'étendue de livraison le permet – est conforme aux exigences essentielles applicables de la directive Machines (2006/42/CE).

La quasi-machine satisfait en outre aux exigences de la/des directive(s) suivante(s) :

Directive(s) CE : Compatibilité électromagnétique 2004/108
Directive Basse Tension 2006/95

Normes harmonisées : EN 12100-1, EN 12100-2, EN 60204-1, EN 14121-1,
EN 55014-1, EN 55014-2, EN 61000-6-2,
EN 61000-3-12, EN 61000-3-11 (Z_{max}), EN 50366, EN 62233,
EN 60335-2-45

De plus, nous confirmons également que la documentation technique spécifique à cette quasi-machine a été préparée conformément à l'Annexe VII (Partie B) et nous nous engageons à la remettre aux autorités de surveillance du marché par voie électronique.

Nom du responsable de la documentation : Patrick Rieder, Responsable de la conformité

La mise en service de cette quasi-machine est interdite tant qu'il n'a pas été constaté que la machine dans laquelle elle doit être incorporée est conforme aux dispositions de la directive Machines (2006/42/CE).

Kaegiswil, 01.07.2011

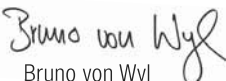
Bruno von Wyl
Directeur technique

Christiane Leister
Propriétaire de l'entreprise

Elimination



Les appareils électriques, accessoires et emballages doivent être recyclés dans le respect de l'environnement. **Uniquement pour les pays européens** : Ne jetez pas les appareils électriques dans les déchets ménagers ! Conformément à la directive européenne 2002/96 relative aux déchets d'équipements électriques et électroniques et à son application au droit national, les appareils électriques usagés doivent être collectés séparément et recyclés dans le respect de l'environnement.

Caractéristiques techniques

Type		BASIC		SYSTEM		
Tension	V~	3 × 400	3 × 480	3 × 230	3 × 400	3 × 400
Fréquence	Hz	50/60		50/60		
Puissance	kW	32		28	11	32
Débit d'air min.	l/min.	3800		2200	1100	3100
Température max.	°C	650		650		
Température ambiante	°C	<60		<60		
Température d'entrée d'air max	°C	<50		<50		
Niveau d'émission	L _{pA} (dB)	<70		<70		
Poids	kg	13.5		13.5		
Dimensions	mm	447 × 312 × 306		447 × 312 × 306		
Signe de conformité		CE		CE		
Signe de protection						
Type de certification						
Classe de protection I		⊕		⊕		

Sous réserve de modifications techniques

Description de l'appareil

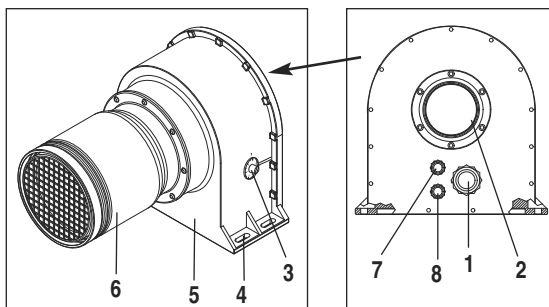

- 1 Raccord fileté pour connexion secteur
- 2 Tubulure d'injection \varnothing 60 ou \varnothing 90
- 3 Potentiomètre pour réglage de puissance
- 4 Socle de montage
- 5 Boîtier
- 6 Tuyau de la résistance avec fourreau de protection
- 7 Raccord fileté pour connexion de la commande 4–20 mA ou 0–10 V
- 8 Raccord fileté pour contact d'alarme
- 9 Inverseur Potentiomètre / Interface
En bas : Potentiomètre
En haut : Interface
- 10 Interface
- 11 Contact d'alarme

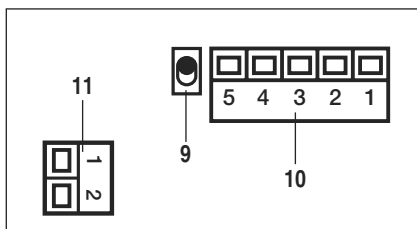

Montage

- L'appareil doit être fixé à l'aide de quatre vis au niveau du **socle de montage (4)**.
- Le montage doit garantir
 - que seul de l'air froid est introduit
 - qu'aucun échauffement ne se produit
 - que le jet d'air chaud d'un autre dispositif ne balaye pas l'appareil.
- Protégez l'appareil des vibrations mécaniques et des secousses.

Dimensions d'installation en mm

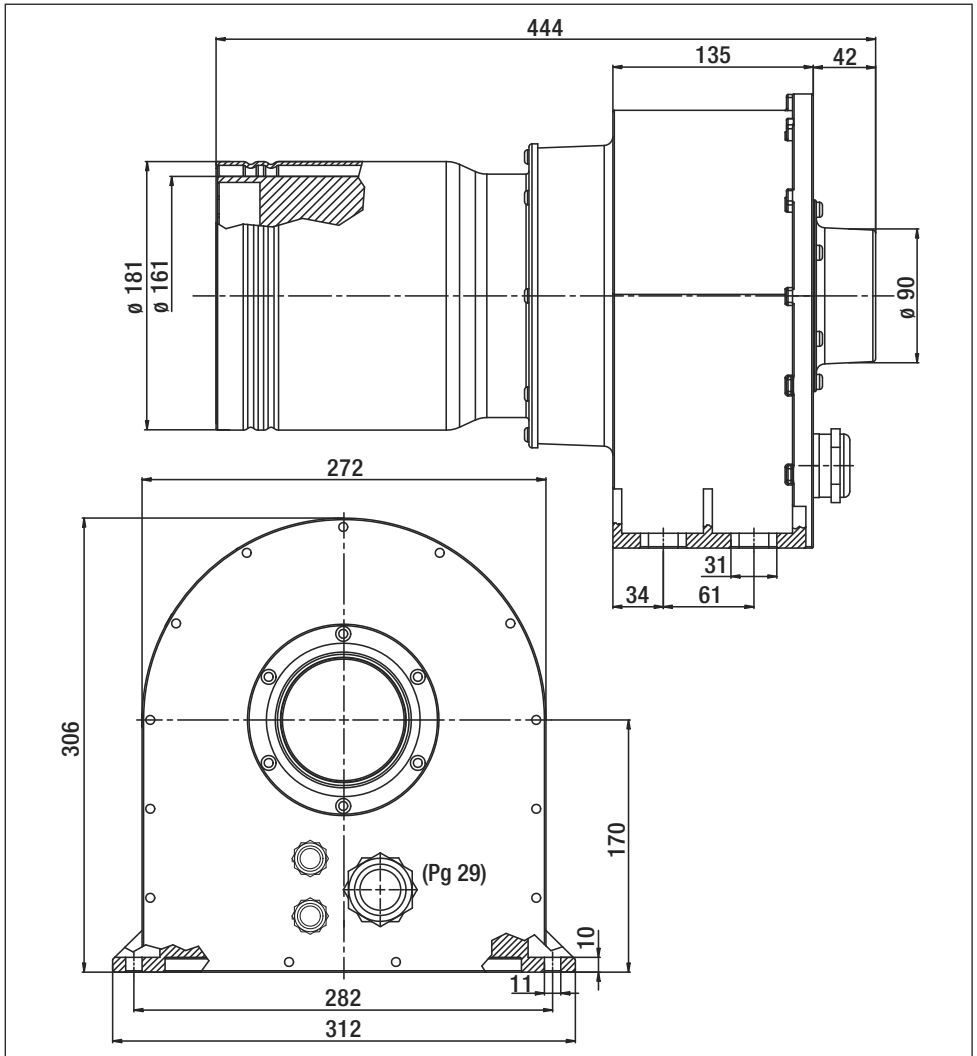

Alimentation en air

- Pour protéger l'appareil et la résistance, le débit d'air minimal prescrit ne doit en aucun cas être dépassé vers le bas et la température maximale (point le plus chaud mesuré 3 mm en amont du **tuyau de la résistance (6)**) ne doit en aucun cas être dépassée vers le haut. Si le débit d'air minimal est dépassé vers le bas, la puissance de chauffe doit immédiatement être interrompue.
- Respectez le sens du débit d'air.
- La température d'entrée d'air maximale prescrite ne doit en aucun cas être dépassée!
- Des souffleries Leister doivent être utilisées comme alimentation en air (respectez le sens de rotation et le chauffage de compression).
- Si l'air est chargé de poussières, utilisez un filtre en acier inoxydable au niveau du manchon d'aspiration de la soufflerie. Si les poussières sont particulièrement critiques (par exemple poussières métalliques, électroconductrices ou humides), des filtres spéciaux doivent être utilisés pour éviter des courts-circuits dans l'appareil.

Attention : Toujours faire fonctionner l'appareil avec l'alimentation en air !

Schéma des connexions du bloc d'alimentation

- L'appareil doit être raccordé par un personnel spécialisé conformément au schéma des connexions.
- Le câble de raccordement doit présenter une section adéquate du conducteur.
- Assurez-vous que les câbles d'alimentation ne touchent pas le tuyau de la résistance et qu'ils ne sont pas exposés au jet d'air chaud.

S1: Un dispositif adéquat de séparation du secteur sur tous les pôles doit être présent dans la connexion secteur, avec une distance entre contacts de 3 mm.

Schéma des connexions :

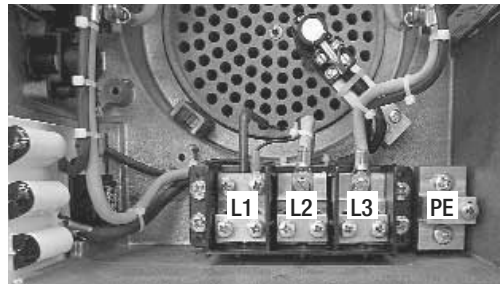
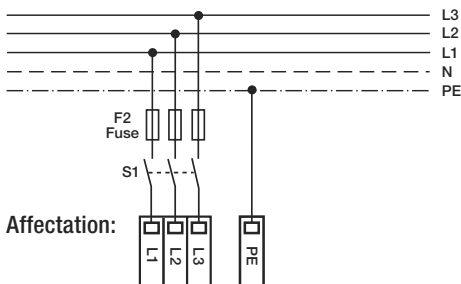

Interface système LHS 91 SYSTEM

La puissance de l'appareil peut être commandée via l'**interface (10)** avec les signaux I_C 4–20 mA ou U_C 0–10 V. Une alimentation U_S 15–26 VCC est également nécessaire. L'**interrupteur (9)** doit être positionné en haut.

Affectation des broches (10)

1	U_S GND	
2	U_C 0–10V	
3	I_C 4–20 mA	
4	I_C GND	
5	U_S	

Caractéristiques techniques

Alimentation	U_S	15–26 VCC
	U_S max.	26 VCC
	Courant absorbé à 24 VCC	12 mA
Courant de commande	I_C	4–20 mA
	I_C Rippel max.	< 0.1 mA
	I_C max.	22 mA
	Résistance d'entrée (typ.)	230 Ohm
Tension de commande	U_C	0–10 VCC
	U_C Rippel max.	< 0.05 VCC
	U_C max.	12 VCC
	Résistance d'entrée (typ.)	280 kOhm

Commande 4–20 mA

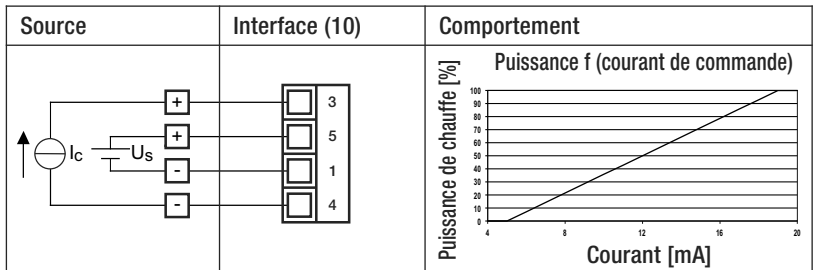

Commande 0–10 VCC

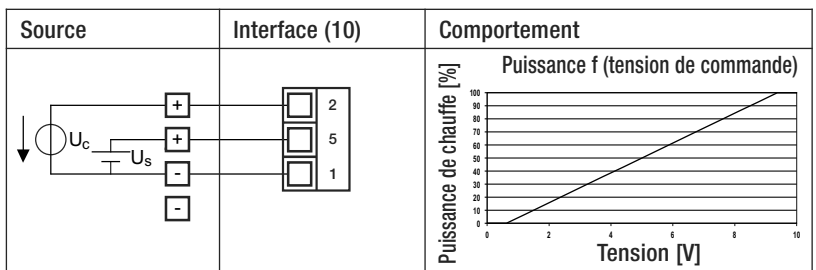

Alarme LHS 91 SYSTEM

Caractéristiques techniques :
Contacts du relais SPST - NO
250V / 30 VDC, 3A $\cos \varphi = 1$

Affectation des broches (11)



Utilisation régulée LHS 91 SYSTEM

Régulateur de température CSS

4–20 [mA]
0–10 [V]

LHS 91 SYSTEM



Thermocouple

Utilisation commandée LHS 91 SYSTEM

Régulateur de température CSS

4–20 [mA]
0–10 [V]
0–100 %

LHS 91 SYSTEM



Potentiomètre externe

4–20 [mA]
0–10 [V]
0–100 %

LHS 91 SYSTEM



Fonctionnement

- Selon les besoins, montez la buse ou le réflecteur correspondant.
- Vérifiez que l'air chaud puisse s'échapper librement, auquel cas l'appareil peut être endommagé en raison d'un échauffement (risque d'incendie !).
- ATTENTION : Respectez le débit d'air minimal conformément aux caractéristiques techniques.
- Activez le secteur.
- Laissez refroidir l'appareil après le fonctionnement du chauffage.

Utilisation LHS 91 BASIC

La température peut être influencée uniquement par le débit d'air introduit par l'utilisateur.



ATTENTION : Le débit d'air minimal ne doit en aucun cas être dépassé vers le bas (voir Caractéristiques techniques) ! L'appareil est doté d'une protection de la résistance et de l'appareil !

Utilisation LHS 91 SYSTEM

1. Puissance de chauffe réglable en continu avec le **potentiomètre pour le réglage de puissance (3)**.
REMARQUE : L'**interrupteur (9)** doit être positionné en bas.

ou

2. Puissance de chauffe réglable en continu via la **connexion de commande (7)** avec **interface (10)**.
REMARQUE : L'**interrupteur (9)** doit être positionné en haut.

- **Fonction Protection de la résistance**

Si la résistance est menacée de surchauffe, l'apport de puissance vers la résistance est réduit.

- **Fonction Protection de l'appareil**

Si l'appareil est menacé de surchauffe (apport d'air trop chaud, échauffement, manque d'air), l'apport de puissance vers la résistance est interrompu et le contact de travail du **relais d'alarme (11)** est ouvert. Ceci peut être exploité en option pour identifier les défauts.

- **Mesures en cas de réponse de la protection de l'appareil**

- Pour pouvoir redémarrer l'appareil, il doit être débranché du secteur électrique pendant 5 secondes.
- Contrôlez l'alimentation en air.
- Contrôlez le débit d'air.
- Contrôlez le passage de l'air.
- Reliez à nouveau l'appareil au secteur électrique.



Remplacement de buses ou de réflecteurs



Risque de brûlure ! Ne touchez pas le tuyau de la résistance et la buse s'ils sont chauds. Avant le remplacement de buses ou de réflecteurs, laissez refroidir l'appareil.

Formation

Leister Process Technologies et ses points service compétents proposent des cours gratuits relatifs aux applications.

Dessins 3D

Les dessins 3D des chauffe-air de la gamme LHS sont disponibles auprès de votre point service ou sur www.leister.com.

Accessoires

Seuls des accessoires Leister doivent être utilisés.

- Leister offre une vaste gamme d'accessoires, par exemple
 - Régulateurs de température
 - Buses
 - Soufflerie
- Accessoires à l'adresse www.leister.com

Maintenance et réparation

- Les réparations doivent être réalisées exclusivement par les **points service Leister** compétents. Ils garantissent un **service de réparation** approprié et fiable avec des pièces d'origine, conformément aux schémas de câblage et aux listes des pièces de rechange.

Garantie

- L'appareil est couvert par une garantie de base d'un (1) an à compter de la date d'achat (prouvée grâce à la facture ou au bon de livraison). Une livraison de remplacement ou des réparations permettent de corriger les dommages survenus. Les résistances sont exclues de cette garantie.
- Toute autre prétention est exclue, sous réserve des dispositions légales applicables.
- Les dommages imputables à l'usure naturelle, à une surcharge ou à une manipulation non conforme sont exclus de la garantie.
- Toute prétention est exclue pour les appareils qui ont été transformés ou modifiés par l'acheteur.



Lea atentamente las instrucciones de funcionamiento antes de la puesta en marcha y consérvelas para usos futuros.

LHS 91 BASIC / LHS 91 SYSTEM

Calentador de aire

Aplicación

Los calentadores de aire LHS 91 BASIC y LHS 91 SYSTEM están indicados para su montaje en máquinas, instalaciones o aparatos y han sido diseñados para el funcionamiento continuo.

- **Procesos de secado o calentamiento** de las más distintas clases
- **Retracción y soldadura** de plástico de embalaje y piezas de moldeo
- **Calentamiento** de hornos continuos y recipientes
- **Activación y desprendimiento** de adhesivos y pegamentos en caliente sin disolventes
- **Esterilización** de materiales de envasado como botellas, corchos y recipientes
- **Separación y fundición** de hilos y tejidos sintéticos
- **Procesos de soldadura** en piezas de chapa fina
- **Aceleración** de procesos de mezcla y **disolución** de espumas que se forman en los procesos de mezcla o llenado
- **Soldadura** de termoplásticos
- **Desbarbado** de piezas de plástico
- **Abrillantamiento** de superficies de plástico



Advertencia



Peligro de muerte al abrir el aparato, ya que se dejan al descubierto componentes y conexiones sometidos a tensión. Antes de abrir el aparato, éste debe estar completamente desconectado de la red.



Peligro de incendio y explosión en caso de un uso inadecuado de los calentadores de aire, en especial cerca de materiales inflamables y gases explosivos.



¡Peligro de quemaduras! No toque el tubo calentador ni la boquilla si están calientes. Espere a que el aparato se enfríe. No dirija el chorro de aire caliente hacia personas o animales.



Precaución



La **tensión nominal** indicada en el aparato debe coincidir con la tensión de red.

IEC/EN 61000-3-11; $Z_{max} = 0.065\Omega + j 0.040\Omega$. En caso necesario, consulte a la empresa de suministro eléctrico.



Los aparatos con clase de protección I deben ponerse a tierra con conductor de protección.



El equipo **debe permanecer vigilado** mientras esté funcionando.

El calor puede llegar a materiales inflamables que no se encuentran a la vista. El aparato sólo debe ser utilizado **por personal especializado** debidamente formado o bajo su vigilancia. Se prohíbe terminantemente su uso por parte de niños.



Proteger el aparato de la **humedad y el agua.**

Declaración de montaje

(a efectos de la directiva sobre máquinas de la CE 2006/42, anexo II B)

Por la presente, **Leister Process Technologies, Galileostrasse 10, CH-6056 Kaegiswil/Suiza** declara que la máquina incompleta

Denominación: **Air Heater**
Tipo: **LHS 91**
Modelo: **BASIC o SYSTEM**

cumple los requisitos fundamentales aplicables de la directiva sobre máquinas de la CE (2006/42), en la medida en que el volumen de suministro lo permita.

La máquina incompleta cumple además los requisitos de la(s) siguiente(s) directiva(s) de la CE:

Directiva(s) de la CE: Compatibilidad electromagnética 2004/108
Directiva de baja tensión 2006/95

Normas armonizadas: EN 12100-1, EN 12100-2, EN 60204-1, EN 14121-1,
EN 55014-1, EN 55014-2, EN 61000-6-2,
EN 61000-3-12, EN 61000-3-11 (Z_{max}), EN 50366, EN 62233,
EN 60335-2-45

Por lo demás, declaramos que la documentación técnica especial para esta máquina incompleta se ha elaborado según el anexo VII (parte B) y nos comprometemos a transmitirla por vía electrónica a las autoridades de control de mercado cuando se nos solicite justificadamente.

Nombre del responsable de la documentación: Patrick Rieder, Compliance Manager.

La puesta en funcionamiento de la máquina incompleta queda prohibida hasta que, en caso necesario, se constate que la máquina en la que esta máquina incompleta se ha instalado cumple las disposiciones de la directiva sobre máquinas de la CE (2006/42).

Kaegiswil, 01.07.2011

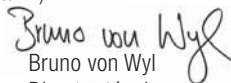
Bruno von Wyl
Director técnico

Christiane Leister
Propietaria de la empresa

Eliminación



Los equipos eléctricos, accesorios y embalajes deben ser reciclados ecológicamente. **Solo para países de la UE:** ¡No tire equipos eléctricos a la basura! Según la directiva europea 2002/96 sobre residuos de aparatos eléctricos y electrónicos y su aplicación en derecho nacional, los equipos eléctricos que ya no se pueden usar deben ser recogidos por separado y reciclados ecológicamente.

Datos técnicos

Typo		BASIC		SYSTEM		
Tensión	V~	3 × 400	3 × 480	3 × 230	3 × 400	3 × 400
Frecuencia	Hz	50/60		50/60		
Potencia	kW	32		28	11	32
Caudal mínimo de aire	l/min.	3800		2200	1100	3100
Temperatura máxima	°C	650		650		
Temperatura ambiente	°C	<60		<60		
Temperatura máx. del aire de admisión	°C	<50		<50		
Nivel de emisiones	L _{pA} (dB)	<70		<70		
Peso	kg	13.5		13.5		
Dimensiones	mm	447 × 312 × 306		447 × 312 × 306		
Símbolo de conformidad		CE		CE		
Símbolo de seguridad						
Tipo de certificado						
Clase de protección I		⊕		⊕		

Sujeto a modificaciones técnicas

Descripción del aparato

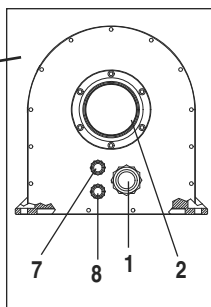
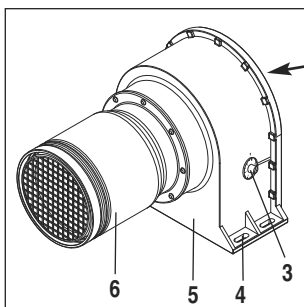

1. Conexión roscada para el cable de red
2. Boca de toma de aire de 60 o 90 de ø
3. Potenciómetro para el ajuste de potencia
4. Pie de montaje
5. Carcasa
6. Tubo calentador con tubo protector
7. Conexión roscada para el cable de mando 4–20 mA o 0–10 V
8. Conexión roscada para el cable de contacto de alarma
9. Conmutador potenciómetro / interfaz
Abajo: potenciómetro
Arriba: interfaz
10. Interfaz
11. Contacto de alarma

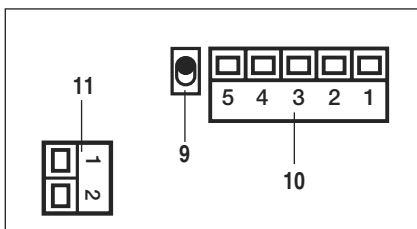

Montaje

- El aparato debe fijarse al **pie de montaje (4)** con cuatro tornillos.
- El montaje debe garantizar que
 - sólo se alimente aire frío
 - no se retenga el calor
 - el aparato no reciba el chorro de aire caliente de otro aparato.
- Proteja el aparato de vibraciones mecánicas y sacudidas.

Dimensiones de montaje en mm

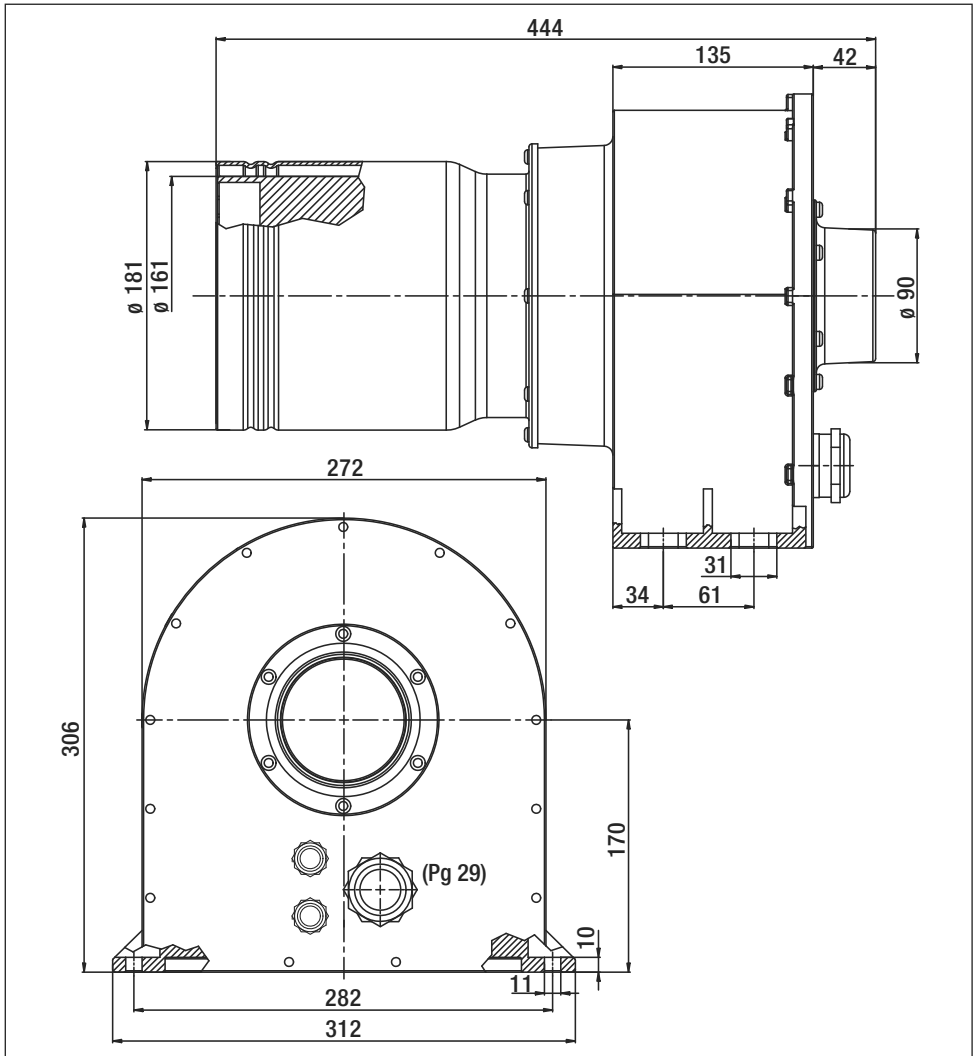

Alimentación de aire

- Para proteger el aparato y el elemento calentador, el caudal de aire no debe estar nunca por debajo del caudal mínimo establecido y la temperatura máxima (medida en el punto más caliente, 3 mm antes del **tubo calentador (6)**) no debe superarse en ningún caso. Si no se alcanza el caudal de aire mínimo, la potencia de calentamiento debe interrumpirse de inmediato.
- Observe la dirección del flujo de aire.
- ¡La temperatura máxima establecida para el aire de admisión no debe superarse!
- Para la alimentación de aire deben utilizarse soplantes de Leister (observe la dirección de giro y el calentamiento de compresión).
- Si el nivel de polvo en el aire es alto, utilice un filtro de acero inoxidable para la toma de aire del soplante. En el caso de partículas especialmente problemáticas (de metal, conductoras de electricidad o húmedas) deberán utilizarse filtros especiales para evitar cortocircuitos en el aparato.

Atención: Utilice el aparato siempre con alimentación de aire.

Esquema de conexiones del componente de potencia

- La conexión del aparato debe ser realizada por personal cualificado siguiendo el esquema de conexiones.
- El cable de conexión de red debe tener la sección de conductor adecuada.
- Asegúrese de que los cables de conexión no toquen el tubo calentador y no estén expuestos al chorro.

S1: La conexión de red debe disponer de un dispositivo adecuado que asegure la completa desconexión de la red con una **distancia de contacto de 3 mm**.

Esquema de conexiones:

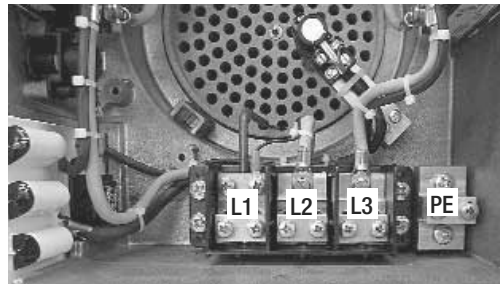
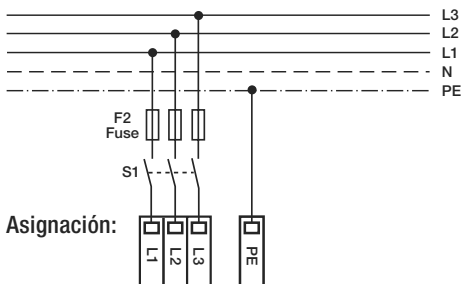

Interfaz de sistema LHS 91 SYSTEM

La potencia del aparato puede controlarse a través de la **interfaz (10)** con las señales IC 4–20 mA o UC 0–10V. Para ello se requiere una alimentación adicional US 15–26VCC. El **interruptor (9)** debe estar hacia arriba.

Asignación de clavijas (10)

1	U_S GND	
2	U_C 0–10V	
3	I_C 4–20 mA	
4	I_C GND	
5	U_S	

Datos técnicos

Alimentación	U_S	15–26 VCC
	U_S Máx.	26 VCC
	Consumo de corriente a 24 VCC	12 mA
Corriente de control	I_C	4–20 mADC
	I_C Ríppel Máx.	< 0.1 mADC
	I_C Máx.	22 mADC
	Impedancia de entrada (típ.)	230 Ohm
Tensión de control	U_C	0–10 VCC
	U_C Ríppel Máx.	< 0.05 VCC
	U_C Máx.	12 VCC
	Impedancia de entrada (típ.)	280 kOhm

Activación 4–20 mA

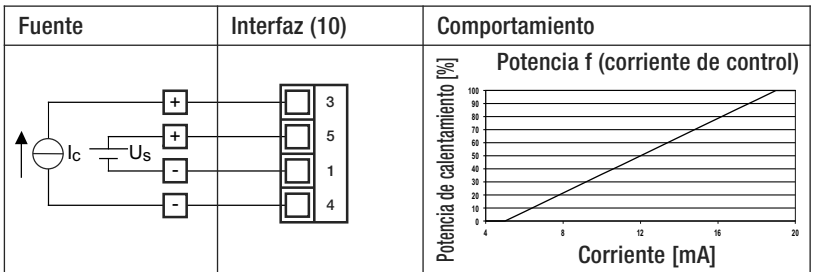

Activación 0–10 VCC

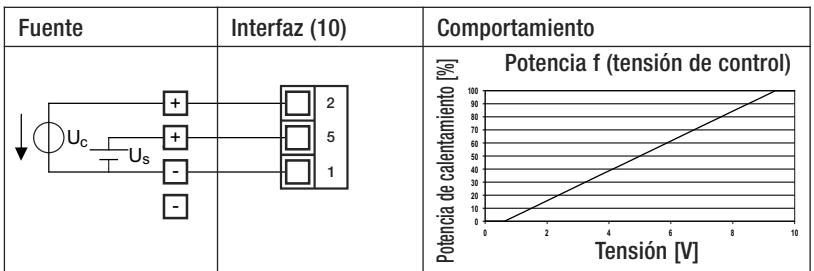

Alarma LHS 91 SYSTEM

Datos técnicos:

Contacto de relé SPST - NO
250V / 30 VCC, 3A $\cos \varphi = 1$

Asignación de clavijas (11)



Aplicación con regulación LHS 91 SYSTEM

Temperatura de controlador CSS

4–20 [mA]
0–10 [V]

LHS 91 SYSTEM



Termopar

Aplicación con control LHS 91 SYSTEM

Temperatura de controlador CSS

4–20 [mA]
0–10 [V]
0–100 %

LHS 91 SYSTEM



Potenciometro externo

4–20 [mA]
0–10 [V]
0–100 %

LHS 91 SYSTEM



Funcionamiento

- En caso necesario, monte la boquilla o el reflector que corresponda.
- Debe asegurarse de que el aire caliente pueda salir libremente, ya que una retención de aire caliente puede causar daños en el aparato (¡peligro de incendio!).
- ATENCIÓN: Respete el caudal de aire mínimo indicado en los datos técnicos.
- Conecte la alimentación de red.
- Deje enfriar el aparato tras el funcionamiento en caliente.

Manejo del LHS 91 BASIC

La temperatura sólo puede modificarse mediante el caudal de aire aplicado por el usuario.



ATENCIÓN: ¡El caudal de aire no debe estar por debajo del mínimo establecido (consulte los datos técnicos)! ¡El aparato no dispone de una protección del elemento calentador y del aparato integrada!!

Manejo del LHS 91 SYSTEM

1. La potencia de calentamiento puede ajustarse sin escalas con el **potenciómetro para el ajuste de potencia (3)**.
NOTA: El **interruptor (9)** debe estar hacia abajo.

0

2. La potencia de calentamiento puede ajustarse sin escalas a través de la **conexión de control (7)** con **interfaz (10)**.
NOTA: El **interruptor (9)** debe estar hacia arriba.

• Funcionamiento de la protección del elemento calentador

Si el elemento calentador se acerca al sobrecalentamiento, la alimentación de potencia al elemento calentador se reduce.

• Funcionamiento de la protección del aparato

Si el aparato se acerca al sobrecalentamiento (aire de alimentación demasiado caliente, retención de aire caliente, falta de aire), se interrumpe la alimentación de potencia al elemento calentador y se abre el contacto de trabajo del **relé de alarma (11)**. Éste puede evaluarse opcionalmente para el reconocimiento de errores.

• Medidas tras la activación de la protección del aparato

- Para que el aparato pueda reiniciarse, éste debe desconectarse de la red eléctrica durante 5 segundos.
- Compruebe la alimentación de aire.
- Compruebe el caudal de aire.
- Compruebe el paso del aire.
- Vuelva a conectar el aparato a la red eléctrica.



Cambio de boquilla o reflector



¡Peligro de quemaduras! No toque el tubo calentador ni la boquilla si están calientes. Antes de cambiar la boquilla o el reflector, espere a que se enfríe el aparato.

Formación

Leister Process Technologies, así como sus puntos de servicio autorizados, ofrecen cursos gratuitos sobre las aplicaciones.

Diseños en 3D

Si desea diseños en 3D de la línea de calentadores de aire LHS, los encontrará en su punto de servicio o en www.leister.com.

Accesorios

Sólo deben utilizarse accesorios de Leister.

- Leister le ofrece una amplia gama de accesorios, como, por ejemplo:
 - Reguladores de temperatura
 - Boquillas
 - Soplantes
- Puede adquirir los accesorios a través de www.leister.com

Servicio y reparaciones

- Las reparaciones sólo deben realizarse en **puntos de servicio técnico** autorizados por Leister. Éstos garantizan un **servicio de reparación** fiable y especializado con piezas de repuesto originales conforme a los planos de conexiones y las listas de piezas de repuesto.

Garantía

- Para este aparato existe una garantía básica de un (1) año a partir de la fecha de compra (justificable con recibo de compra o albarán de entrega). Los daños que se produzcan se subsanarán mediante reparación o sustitución. Los elementos calentadores no se incluyen en esta garantía.
- Quedan excluidos otros derechos, salvo por disposiciones legales.
- Quedan excluidos de la garantía los daños atribuidos al desgaste natural, la sobrecarga o el uso inadecuado del aparato.
- No existe ningún derecho en aparatos reformados o modificados por el comprador.



Kullanım kılavuzunu, cihazı işleme almadan önce dikkatle okuyun ve daha sonra başvurmak üzere saklayın.

LHS 91 BASIC / LHS 91 SYSTEM

Sıcak Hava Cihazı

Kullanım

Leister LHS 91 BASIC ve LHS 91 SYSTEM sıcak hava cihazları, makinelere, tesislere veya cihazlara monte etmek için uygundur ve kesintisiz işletim için tasarlanmıştır.

- Değişik türde **kurutma ve ısıtma işlemleri**
- Ambalaj folyolarının ve kalıp parçalarının **büzülmesi ve kaynak yapılması**
- Taşıma bantlı geçiş fırınlarının ve depoların **ısıtılması**
- Solvent içermeyen yapıştırma maddelerinin ve sıcak yapıştırıcıların **aktive edilmesi ve çözülmesi**
- Şişeler, mantarlar ve kaplar gibi ambalaj malzemelerinin **sterilize edilmesi**
- Sentetik liflerin ve dokuların **ayrılması ve eritilmesi**
- İnce sac parçalarda **lehim işlemleri**
- Karıştırma proseslerinin **hızlandırılması** ve karıştırma veya doldurma işlemleri sırasında oluşan köpüklerin **ortadan kaldırılması**
- Termoplastik malzemelerin **kaynak işlemi**
- Plastik pres çapaklarının **temizlenmesi**
- Plastik yüzeylerin **parlatılması**



Uyarı



Elektrik bulunan bileşenler ve bağlantılar açığa çıkacağı için cihaz açılırken **hayati tehlike** vardır. Cihaz açılmadan önce, cihazın **tüm kutupları** elektrik şebekesinden ayrılmalıdır.



Sıcak hava cihazlarının, özellikle yanıcı malzemelerin ve patlayıcı gazların yakınında usulüne uygun olarak monte edilmemesi ve kullanılmaması durumunda **yangın ve patlama tehlikesi** vardır.



Yanma tehlikesi! Sıcak durumdaki ısıtma elemanı borusuna ve memeye dokunmayın. Cihazı soğumaya bırakın. Cihazdan çıkan sıcak havayı insanlara veya hayvanlara doğru tutmayın.



Dikkat



Cihazın üzerinde belirtilen **anma gerilimi**, şebeke gerilimi ile eşdeğer olmalıdır. IEC/EN 61000-3-11; $Z_{maks} = 0.065\Omega + j 0.040\Omega$. Gerekliğinde elektrik dağıtım şirketine danışın.



Koruma sınıfı I kapsamındaki cihaz, bir koruma iletkeni ile topraklanmalıdır.



Cihaz, **gözlem altında tutularak** çalıştırılmalıdır. Oluşan ısı, görüş alanının dışında kalan yanıcı malzemelere ulaşabilir. Cihaz, sadece **eğitilmiş uzman personel** tarafından veya bunların gözetimi altında kullanılmalıdır. Çocuklar tarafından kullanılması kesinlikle yasaktır.



Cihaz, **neme ve suya karşı korunmalıdır.**

Donanım Ekleme Beyanı

(2006/42/AT sayılı AT Makine Emniyeti Yönetmeliği Ek II B uyarınca)

Leister Process Technologies, Galileostrasse 10, CH-6056 Kaegiswil/İsviçre, bu kısmen tamamlanmış makinenin,

Tanım: **Air Heater**
Tip: **LHS 91**
Model: **BASIC or SYSTEM**

– teslimat kapsamı bakımından mümkün olduğu kadar AT Makine Emniyeti Yönetmeliği'nin (2006/42) uygulanabilir temel hükümlerine uygun olduğunu beyan eder.

Kismen tamamlanmış makine, ayrıca aşağıda belirtilen AT yönetmeliğinin (yönetmeliklerinin) hükümlerine uygundur:

AT yönetmeliği (yönetmelikleri): Elektromanyetik Uyumluluk 2004/108

Alçak Gerilim Yönetmeliği 2006/95

Harmonize standartlar: EN 12100-1, EN 12100-2, EN 60204-1, EN 14121-1,

EN 55014-1, EN 55014-2, EN 61000-6-2,

EN 61000-3-12, EN 61000-3-11 (Z_{maks}), EN 50366, EN 62233,

EN 60335-2-45

Bu kısmen tamamlanmış makine için, EK VII (Bölüm B) uyarınca gerekli özel teknik dosyaların düzenlendiğini ve bu teknik dosyaların haklı bir amaçla talep edilmesi halinde pazar denetleme kurumlarına elektronik yolla iletileceğini beyan ediyoruz.

Teknik dosya düzenleyen yetkilinin adı: Patrick Rieder, Compliance Manager

Kismen tamamlanmış bu makine, ancak monte edileceği makinenin 2006/42/AT sayılı AT Makine Emniyeti Yönetmeliği'nin hükümlerine uygun olduğu tespit edildiğinde işleme alınabilir.

Kaegiswil, 01.07.2011

Bruno von Wyl
Bruno von Wyl
Teknik Müdür

Christiane Leister
Christiane Leister
Firma Sahibi

İmha Edilmesi



Elektrikli aletler, aksesuarlar ve ambalajlar, çevreye uygun bir şekilde geri dönüşüm sistemine dahil edilmelidir. **Sadece AB ülkeleri için:** Elektrikli ve elektronik aletleri ev çöpüne atmayın! Elektrikli ve elektronik eski cihazlar hakkındaki 2002/96 sayılı Avrupa direktifi ve bu direktifin ulusal yasalar uyarlanmış hali uyarınca kullanılabilir durumda olmayan elektrikli aletler ayrı olarak toplanmalı ve çevreye uygun bir şekilde geri dönüşüm sistemine dahil edilmelidir.

Teknik Veriler

Tip		BASIC		SYSTEM		
Gerilim	V~	3 × 400	3 × 480	3 × 230	3 × 400	3 × 400
Frekans	Hz	50/60		50/60		
Güç	kW	32		28	11	32
Asgari hava miktarı	l/min.	3800		2200	1100	3100
Maksimum sıcaklık	°C	650		650		
Ortam sıcaklığı	°C	<60		<60		
Maks. giriş havası sıcaklığı	°C	<50		<50		
Emisyon seviyesi	L _{pA} (dB)	<70		<70		
Ağırlık	kg	13.5		13.5		
Ölçü	mm	447 × 312 × 306		447 × 312 × 306		
Uygunluk işareti		CE		CE		
Emniyet işareti						
Sertifikalandırma türü						
Koruma sınıfı I		⊕		⊕		

Teknik değişiklik yapma hakkı saklıdır

Cihazın Tanıtımı

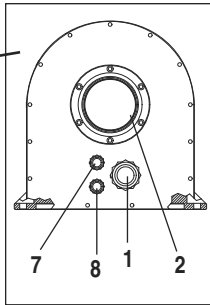
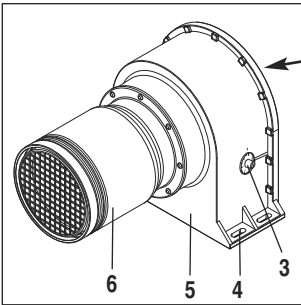

- 1 Elektrik şebekesi bağlantısı için kablo rakoru
- 2 Hava giriş bağlantısı \varnothing 60 veya \varnothing 90
- 3 Güç ayarı için potansiyometre
- 4 Montaj ayağı
- 5 Gövde
- 6 Koruma borulu ısıtma elemanı borusu
- 7 Kontrol bağlantısı
4 - 20 mA veya 0 - 10 V
için kablo rakoru
- 8 Alarm kontağı için kablo rakoru
- 9 Potansiyometre / Arabirim değiştirme şalteri
Alt: Potansiyometre
Üst: Arabirim
- 10 Arabirim
- 11 Alarm kontağı

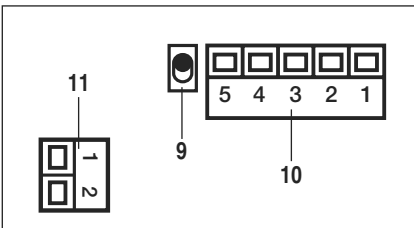

Montaj

- Cihaz, dört cıvata ile **montaj ayağına (4)** tespitlenmelidir.
- Montaj yapıldığında, aşağıda belirtilen hususlar sağlanmış olmalıdır:
 - Sadece soğuk hava girişi olmalıdır.
 - Geriye doğru ısı birikimi olmamalıdır.
 - Cihaz, başka bir cihazdan çıkan sıcak havaya maruz bırakılmamalıdır.
- Cihaz, mekanik titreşimlere ve sarsıntıya karşı korunmalıdır.

mm Olarak Montaj Ölçüleri

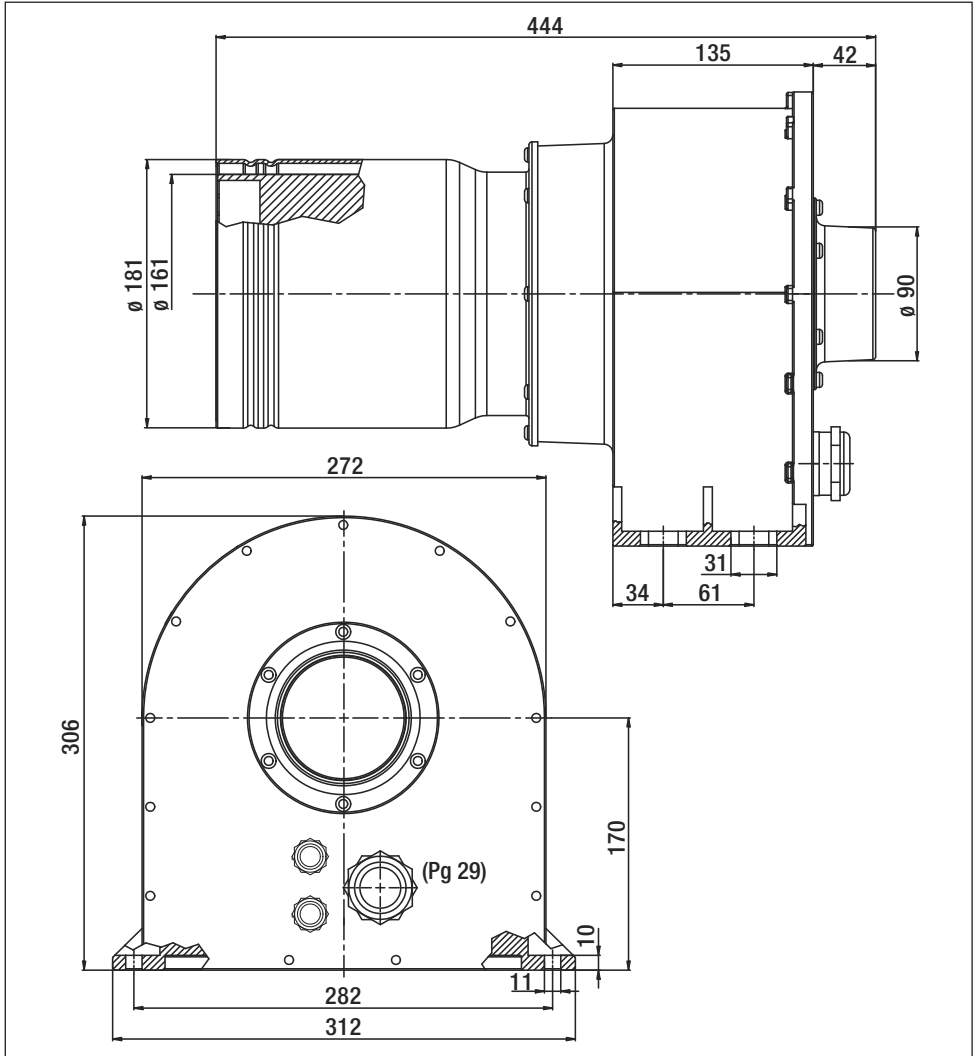

Hava Beslemesi

- Cihazı ve ısıtma elemanını korumak için, öngörülen asgari hava miktarının altına kesinlikle düşülmemeli ve maksimum sıcaklık (**ısıtma elemanı borusunun (6)** 3 mm altında en sıcak yerde ölçülmüş) kesinlikle aşılmamalıdır. Asgari hava miktarının altına düşüldüğünde, ısıtma gücü hemen kesilmelidir.
- Hava akış yönünü dikkate alın.
- Öngörülen maksimum giriş havası sıcaklığı aşılmamalıdır !
- Hava beslemesi olarak Leister fanları kullanılmalıdır (dönme yönü ve sıkıştırılmalı ısıtma dikkate alınmalıdır).
- Hava toz içerdiğinde, fan giriş bağlantısında Leister firmasına ait paslanmaz çelik filtre kullanılmalıdır. Özel yapıdaki tozlarda (örneğin elektriği ileten veya nemli metal tozlar), cihazda muhtemel kısa devrelerin önlenmesi için özel filtre kullanılmalıdır.

Dikkat: Cihazı, her zaman hava beslemesi ile çalıştırın!

Güç Parçası Bağlantı Şeması

- Cihaz, bağlantı şemasına uygun olarak bir uzman kişi tarafından bağlanmalıdır.
- Elektrik bağlantı kablosu, uygun kablo kesitine sahip olmalıdır.
- Bağlantı kablolarının, ısıtma elemanı borusuna temas etmemesi ve püskürtülen sıcak havaya maruz kalması sağlanmalıdır.

S1: Elektrik şebekesi bağlantısında, elektrik şebekesi ile bağlantıyı tüm kutuplardan kesen **3 mm'lik kontak mesafesine** sahip uygun bir donanım mevcut olmalıdır.

Bağlantı şeması:

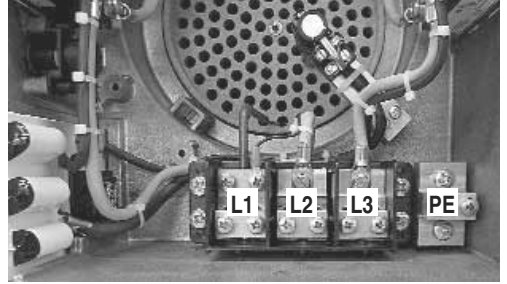
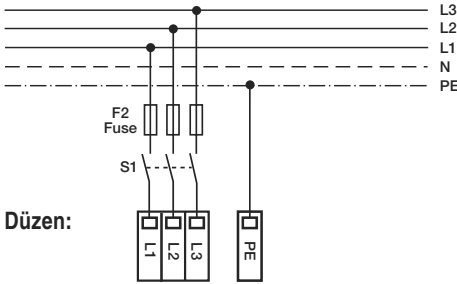

Sistem Arabirimi LHS 91 SYSTEM

Cihazın gücü, **arabirim (10)** üzerinden I_C 4 – 20 mA veya U_C 0 – 10 V sinyalleri ile kontrol edilebilir. Ek olarak bir U_S 15 – 26VDC beslemesi gereklidir. **Şalter (9)** yukarı konumda olmalıdır.

Pin düzeni (10)

1	U_S GND
2	U_C 0–10 V
3	I_C 4–20 mA
4	I_C GND
5	U_S

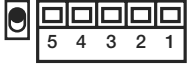

Teknik veriler

Gerilim beslemesi	U_S	15 – 26 VDC
	U_S Maks.	26 VDC
	24 VDC'deki güç çekişi	12 mA
Kumanda akımı	I_C	4 – 20 mA DC
	I_C Rippel Maks.	< 0.1 mA DC
	I_C Maks.	22 mA DC
	Giriş direnci (tipik)	230 Ohm
Kumanda gerilimi	U_C	0 – 10 VDC
	U_C Rippel Maks.	< 0.05 VDC
	U_C Maks.	12 VDC
	Giriş direnci (tipik)	280 kOhm

Kumanda 4 – 20 mA

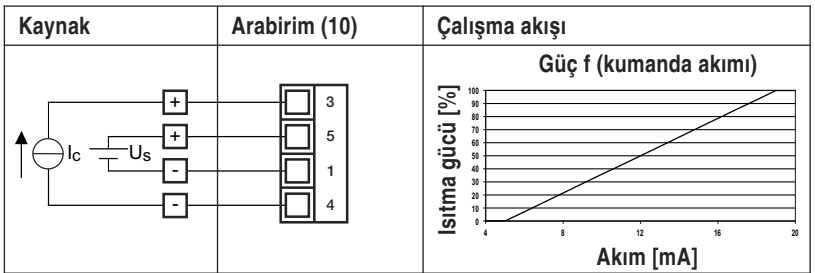

Kumanda 0 – 10 VDC

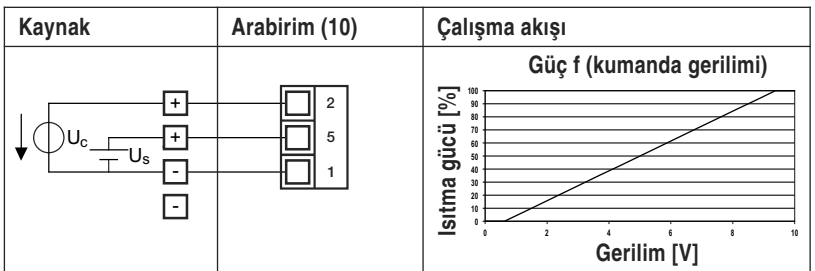

Alarm LHS 91 SYSTEM

Teknik veriler:

Röle kontağı SPST - NO
250V / 30 VDC, 3 A $\cos \varphi = 1$

Pin düzeni (11)

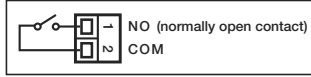

Ayarlamalı Uygulama LHS 91 SYSTEM

Sıcaklık kontrol ünitesi CSS

4 – 20 [mA]
0 – 10 [V]

LHS 91 SYSTEM

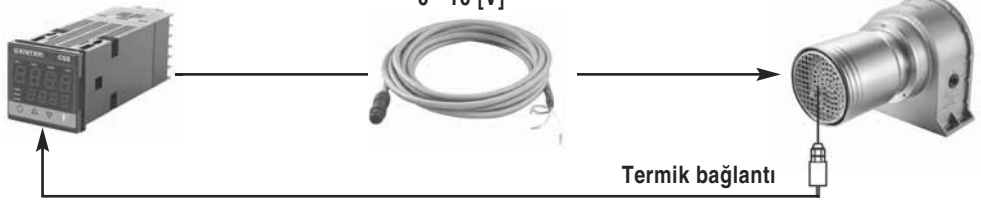

Kontrollü Uygulama LHS 91 SYSTEM

Sıcaklık kontrol ünitesi CSS

4 – 20 [mA]
0 – 10 [V]
0 – 100 %

LHS 91 SYSTEM



Harici potansiyometre

4 – 20 [mA]
0 – 10 [V]
0 – 100 %

LHS 91 SYSTEM



Çalıştırma

- Gerekliğinde uygun meme veya yansıtıcı monte edin.
- Sıcak havanın engellenmeden çıkmasına dikkat edilmelidir. Aksi takdirde, oluşabilecek geriye doğru ısı birikimi cihaza zarar verebilir (yangın tehlikesi!).
- DİKKAT: "Teknik Veriler" altında belirtilen asgari hava miktarına uyulmalıdır.
- Cihazı açın.
- Cihazı, ısıtma çalışmasından sonra soğumaya bırakın.

Kullanım LHS 91 BASIC

Sıcaklık, sadece kullanıcı tarafından beslenen hava miktarı tarafından etkilenebilir.



DİKKAT: Asgari hava miktarının altına düşülmemelidir (bkz. Teknik Veriler)! Cihaz, ısıtma elemanı ve cihaz koruması ile donatılmamıştır!

Kullanım LHS 91 SYSTEM

1. Isıtma gücü, **güç ayarı için potansiyometre (3)** ile kademesiz olarak ayarlanabilir.
BİLGİ: **Şalter (9)** aşağı konumda olmalıdır.
veya
2. Isıtma gücü, **arabirimli (10) kontrol bağlantısı (7)** üzerinden kademesiz olarak ayarlanabilir.
BİLGİ: **Şalter (9)** yukarı konumda olmalıdır.

• Isıtma elemanı koruması fonksiyonu:

Isıtma elemanı aşırı ısınabileceği tehlikesi söz konusu olduğunda, ısıtma elemanına doğru güç beslemesi azaltılır.

• Cihaz koruması fonksiyonu

Cihazın aşırı ısınma tehlikesi söz konusu olduğunda (giriş havası çok sıcak, geriye doğru ısı birikimi, hava yok), ısıtma elemanına doğru güç beslemesi kesilir ve **alarm rölesinin (11)** çalışma kontağı açılır. Bu çalışma kontağı, hata tespiti için opsiyonel olarak değerlendirilebilir.

• Cihaz koruması devreye girdiğinde yapılması gerekenler

- Cihazın yeniden çalıştırılabilmesi için, cihaz yaklaşık 5 saniye süreliğine elektrik şebekesinden ayrılmalıdır.
- Hava beslemesini kontrol edin.
- Hava miktarını kontrol edin.
- Hava geçişini kontrol edin.
- Cihazın elektrik bağlantısını tekrar yapın.



Meme veya Yansıtıcı Değişikliği



Yanma tehlikesi! Sıcak durumdaki ısıtma elemanı borusuna ve memeye dokunmayın. Memeyi veya yansıtıcıyı değiştirirken cihazın soğumasını bekleyin.

Eđitim

Leister Process Technologies firması ve bu firmaya ait yetkili servisler, kullanım ve uygulama konusunda ücretsiz kurslar vermektedir.

3D izimleri

LHS serisi sıcak hava cihazlarının 3D izimleri, yetkili servislerden ve www.leister.com adresinden temin edilebilir.

Aksesuar

Sadece Leister firmasına ait aksesuarlar kullanılabilir.

- Leister firması, oldukça fazla eřit aksesuar sunmaktadır, rneđin
 - Sıcaklık regülatörü
 - Memeler
 - Fan
- Aksesuarlar için bkz. www.leister.com

Servis ve Onarım

- Onarım alıřmaları sadece **yetkili Leister servisleri** tarafından yapılmalıdır. Yetkili servisler, cihazın orijinal yedek paralar kullanılarak devre planlarına ve yedek para listelerine uygun olarak düzgün ve güvenilir bir şekilde onarım hizmeti sunmaktadır.

Garanti

- Cihaz, satın alma tarihinden (Fatura veya sevki irsaliyesi ibrazı şarttır) itibaren 1 yıllık temel bir garantiye sahiptir. Garanti kapsamında meydana gelen hasarlar deđiřim veya onarım yapılarak giderilir. Isıtma elemanları, bu garanti kapsamına dahil deđildir.
- Bunun dıřında, yasal düzenlemeler kayda alınmak sureti ile hiçbir hak talep edilemez.
- Dođal aşınma, aşırı zorlanma veya usulüne uygun olmayan kullanım nedeniyle meydana gelmiř olan hasarlar garanti kapsamı dahilinde deđildir.
- Müřteri tarafından üzerinde modifikasyon veya deđiřiklik yapılan cihazlar için hiçbir hak talep edilemez.



Your authorised Service Centre is:

A large, empty rectangular box with a thin black border, intended for the user to write the name and address of their authorized Leister service center.

Leister Process Technologies
Galileo-Strasse 10
CH-6056 Kaegiswil/Switzerland
Tel. +41 41 662 74 74
Fax +41 41 662 74 16
www.leister.com
sales@leister.com